

BIF003/2-009329-65

cy 1

~~SECRET-SPECIAL HANDLING~~

DEC 1971 INVT

AWO1884

cy 7

~~SECRET~~

12 August 1965

JUN 1965 INVT

AF18(600)-2714

APR

1968 INVT

Sheet count 31

"THIS DOCUMENT FORMERLY WAS AWO1884"

MAY 1969 INVT

SQUARE TWENTY SYSTEM

MAY 1969 INVT

TECHNICAL DESCRIPTION

JUN 1970 INVT

MISSION 7223

SEP 1973 INVT



Prepared by L. J. Doll
L. J. Doll

Approved by A. D. Oros

Approved by [Signature]

HANDLE VIA COMINT
CONTROL POINT ONLY

~~SECRET~~

~~SECRET-SPECIAL HANDLING~~

~~SECRET-SPECIAL HANDLING~~

AWO1884

CONTENTS

	<u>PAGE NUMBER</u>
I. SQUARE-TWENTY SYSTEM SUMMARY	1
A. Mission Objectives	1
B. Signal Of Interest	1
C. System Hardware Description	1
D. System Performance	2
1. Direction Finding Ability	2
2. Receiver System	2
II. ANTENNA SYSTEM	3
A. Pencil Beam Antenna	3
B. Fan Beam Antenna	3
C. Intercept Time Correlation Between The Pencil and Fan Systems	4
D. Probability of Intercept	5
III. PAYLOAD RECEIVER SYSTEM	5
A. General Receiver Description	5
B. RF Section	6
C. Mixer Section	6
D. IF Amplifier Section	6
E. Video Amplifier	7
F. Video Processors	7
1. Wideband Video Amplifier	7
2. Video Peak Detector	7
3. Narrow-Band Filter Detectors	8
G. Receiver Outputs Available For Analysis	10
H. Recognition Signal Outputs	11
I. On-Orbit Calibrator	12

~~SECRET-SPECIAL HANDLING~~

CONTENTS (Continued)

	<u>PAGE NUMBER</u>
J. Voltage-Controlled Oscillators	13
K. Blanking Signals and Band Markers	13
IV. COMPOSITE SYSTEM	14
V. DATA ANALYSIS	14
A. Signal Identification, Measurement, and Video S/N Analysis	14
B. Data Correlation Between Receiver Channels	19
C. Duration of Signal Intercept	19
D. Receiver Link Calculations	19
E. Payload Timing	20
VI. CALIBRATION DATA	21

~~SECRET~~-SPECIAL HANDLING

AW01884

SUPPLEMENTAL INFORMATION

PAGE NUMBER

Payload Receiver Block Diagram - Appendix I	22
Appendix I - Abbreviations	23
Band Marker Identification - Appendix II	24
Orbital System Block Diagram - Appendix III	25
Payload Commutator Instrumentation Schedule - Appendix IV	26
Pencil And Fan Antenna Plots - Appendix V	27

~~SECRET~~-SPECIAL HANDLING

~~SECRET-SPECIAL HANDLING~~

AW01884

I. SQUARE-TWENTY SYSTEM SUMMARY

A. Mission Objectives

The primary objectives of the Square-Twenty System (Mission 7223) are to receive and recognize the desired signal of interest, and to locate its geographical coordinates.

B. Signal Of Interest

The signal of interest is a pulse position modulated (PPM) signal in the frequency range of 1550 to 1750 Mcps (twenty-one 10 Mcps channels). The peak power of the pulsed carrier at the transmitter output terminal is nominally +43 dbm. The signal PW is about 0.5 μ s and average PRF of the composite wave train applied to the transmitter is either 96 or 192 Kcps. The 96 Kcps signal represents 12 data channels, each sampled at an 8 Kcps rate. The signal modulation frequency range per data channel is 300 to 3400 cps.

C. System Hardware Description

The payload system is comprised of two directional antennas, two receivers, a dual channel recorder/reproducer, and a telemetry system. This hardware is mounted on the aft rack of a stabilized Agena which revolves about the earth in a nominal 200 nm polar orbit. The stability of the vehicle will be maintained within $\pm 1.25^\circ$ about the roll, pitch, and yaw axes. The life of the vehicle is anticipated to be 7 to 10 days.

The directional 6° pencil beam antenna is pointed along the vehicle nadir and the energy that it intercepts is presented to the pencil beam receiver channel. The $6^\circ \times 45^\circ$ fan beam antenna is oriented such that the wide portion of its beam is along the vehicle path with the upper and lower 3 db points forming angles of 70° (horizon) and 25° respectively with the vehicle nadir. The fan beam antenna feeds the fan beam receiver channel.

~~SECRET SPECIAL HANDLING~~

~~SECRET~~-SPECIAL HANDLING

AW01884

- 2 -

D. System Performance

1. Direction Finding Ability.

The pencil beam receiver system can geographically locate the target emitter within 20.8 nautical miles, excluding vehicle attitude and timing errors. The fan beam receiver system covers a relatively large geographical area thereby enhancing the probability of intercept. The degree of resolution will vary widely, depending chiefly on the duration of the intercept.

2. Receiver System.

The dual receivers cover the frequency range from 1550 to 1750 Mcps. The target emitter frequency can be measured to within ± 5 Mcps, and the peak power within 3 db from -97 to -57 dbm.

Because of the limited telemetry bandwidth available to convey the received information, a relatively narrow-band video processor is employed, rather than a wide-band video analog device, for the purpose of recognizing the target signal. In each receiver four sharply tuned filters (100 cps bandwidth) are used to monitor the video signal for the presence of four discrete frequency components. Two of these components, 96.0 Kcps and 192.0 Kcps, would normally be contained in the 12 channel target signal, while the other two components, 91.8 Kcps and 191.8 Kcps, would not be present therein.

A simultaneous comparison of the relative amplitudes appearing in each filter provides sufficient information to decide whether or not the received signal was the one of interest.

The four discrete frequency components are down-converted to 150 cps signals, and then frequency multiplexed on the two tracks of the

~~SECRET~~-SPECIAL HANDLING

~~SECRET~~ SPECIAL HANDLING

AW01884

- 3 -

orbital tape recorder. The payload system is turned on over the geographical area of interest. The recorded data are later telemetered to the vehicle tracking stations.

II. ANTENNA SYSTEM

The two antennas are deployed when the vehicle achieves orbit. The pencil beam antenna is directed to intercept the near- 90° side lobes and the fan beam antenna to intercept the main beam and higher amplitude side lobes of the ground emitter antenna, whose main beam (14° horizontal x 8° vertical) is directed toward the horizon for line-of-sight communications.

A. Pencil Beam Antenna

The pencil beam antenna is a 6 ft. diameter parabolic dish which is oriented such that its 6° pencil beam (+26 db directional gain relative to isotropic) is directed along the nadir, or offset by a small angle to optimize intercept probability. The pencil beam pattern projects as a circle on the earth whose diameter, based upon a 200 nm orbit, is 20.8 nm. The field of view includes about 374 square miles and the ground target emitter will be in the field of view for a maximum of 5.2 seconds (assuming the vehicle speed is approximately 4 nm/sec.) depending on its offset from the center of the field of view. The pencil beam antenna provides pinpoint location (within 20.8 nm) by intercepting only the extreme lower amplitude side lobes of the ground emitter antenna (20 to 40 db below isotropic) as the vehicle passes directly overhead.

B. Fan Beam Antenna

The 6° x 45° fan beam antenna, whose directional gain is 17 db relative to isotropic, is a 6 ft. long curved rectangular section (truncated cylindrical dish) with a parabolic taper that is positioned to look straight forward in the direction of vehicle motion with the wide dimension directed

~~SECRET~~ SPECIAL HANDLING

~~SECRET~~ SPECIAL HANDLING

290
AWO1884 116 0 m.m.

- 4 -

along the orbital path. The upper 3 db point of the 45° beam intercepts the earth's horizon at an angle of about 70° with the vehicle nadir, and the lower 3 db point at an angle of 25° with the nadir. The slant ranges for these angles are approximately 1240 and 368 nautical miles respectively. The fan beam projection on the earth is a nominal 11×600 nm long; it is 38 nm wide at the 25° beam point and gradually widens to 130 nm at the horizon.

Coarse positional fix information may be obtained from the fan system by noting the duration of successive intercepts, signal peak power, the time of occurrence, and the period between the intercepts in both channels. If the intercept occurs only in the fan channel this implies that the signal received is either outside the 20.8 nm wide pencil "scribed" path or the lower amplitude side lobes of the signal are of insufficient power to be received.

The attitudes of the fan and pencil antennas may be adjusted slightly from the angles described herein to optimize signal intercept probability.

C. Intercept Time Correlation Between The Pencil And Fan Systems

As the vehicle moves in a northern direction, for example, the fan antenna intercepts ground emitter signals at the horizon whose main beams are pointed in a southern direction and are within the "view" of the fan beam. Then the higher amplitude side lobes of the ground emitter are intercepted, and finally the lower 3 db point passes out of range of the beam about 290 seconds after initial horizon contact. The pencil beam follows in the same path traced out by the fan beam, except that the width of the path is considerably narrower, and should intercept the lower amplitude near -90° side lobes of the same ground emitter approximately 310 seconds after the signal was first seen at the horizon. This assumes that the signal was in the center of the fan beam within ± 10.4 nm when at the horizon.

~~SECRET~~ SPECIAL HANDLING

D. Probability of Intercept

The probability of intercept and the number of intercepts are higher for the fan beam system when compared with the pencil beam system. The directive gain is 9 db less and the signal attenuation due to space loss is up to 15 db more than pencil beam channel, but the fan beam is directed toward the main beam and higher amplitude lobes of the ground emitter signal whereas the pencil system intercepts the near-90° side lobes. Also the area of earth coverage by the fan beam is 97⁴,000 square miles compared to 37⁴ square miles for the pencil beam. Link calculations reveal, assuming the sensitivities at the input to both receiver channels to be -97 dbm that the directive gain of the ground emitter antenna must be equal to or greater than 10 db to be intercepted by the fan beam at the horizon, compared with equal to or greater than -14 db for the 90° side lobes to be intercepted by the pencil beam directly overhead.

III. PAYLOAD RECEIVER SYSTEM

A. General Receiver Description

Electrically the fan beam and the pencil beam receivers are identical, except in their data presentation of the "no modulation" signal outputs as will be described. The receiver block diagram is shown in Appendix I. The two receivers are independent, except that they share common sweep circuitry, local oscillators, blanking circuitry, band marker generator, and on-orbit calibrator. Their sensitivities are -97 dbm; they are synchronously swept-tuned (non-locking) linearly across the 1550 to 1750 Mcps frequency band in 1.8 seconds with an additional 0.2 seconds flyback time. Each new RF sweep begins in synchronism with the vehicle clock. Carrier frequency is measured within ± 5 Mcps by noting the time position of the intercept within the sweep period.

~~SECRET-SPECIAL HANDLING~~

AWOL884

- 6 -

The receivers have linear-logarithmic 3.3 Mcps IF bandwidths capable of compressing 40 db RF dynamic range to 25 db at the output of the video peak detectors. Each receiver employs 4 active narrow-band filter detectors subsequent to its video amplifier for the purpose of identifying whether particular modulation frequencies are present in the signals received. Full particulars concerning the narrow-band filter detectors are given below in part F-3.

B. RF Section

The energies from the fan and pencil beam antennas are fed to the fan and pencil beam receivers, respectively. The following discussion pertains to either receiver channel. The RF energy from the antenna is directed through a low-insertion-loss directional coupler to the fixed-tuned, 200 Mcps pass band, tunnel diode RF amplifier. The RF energy from the on-orbit calibrator also passes through the directional coupler, which serves to isolate (25 db) the antenna and the calibrator. The receiver pass band is further limited by employing 1,925 Mcps low-pass filters on each side of the RF amplifier. The filter response is below 40 db from 2,400 to 5,400 Mcps where the filters again pass the signal. The effective noise figure for the receiver is 5.0 db maximum.

C. Mixer Section

The fixed-band RF energy is mixed with the LO frequency which is tuned linearly from 1520 to 1720 Mcps in 1.8 seconds. The mixer provides 20 db of image signal rejection as a result of using two hybrid 90° couplers, two pairs of balanced modulators, and a hybrid ring power splitter.

D. IF Amplifier Section

The IF section is comprised of a pair of 30 \pm 4 Mcps preamplifiers, each one following a balanced modulator, and a linear-logarithmic 30 \pm 1.65 Mcps

~~SECRET-SPECIAL HANDLING~~

~~SECRET-SPECIAL HANDLING~~

AW01884

- 7 -

amplifier which compresses a 40 db RF input dynamic range to 25 db at the output. The first 10 db of the response is linear. The effective receiver passband for any particular LO frequency is 3.3 Mcps.

A bandpass filter follows the log IF amplifier. It has a 3 db bandwidth of 3.6 Mcps and a 40 db bandwidth of 8.3 Mcps. Its center frequency is 30 Mcps.

E. Video Amplifier

The receiver design, from RF to video, is optimized to provide maximum video output S/N for signals whose pulse widths are nominally 0.5 μ s. The video amplifier preserves the 25 db receiver output dynamic range and provides sufficient signal to drive three video data processors, i.e., (1) via a delay line pulse stretcher and buffer amplifier to provide a wideband 1 Mcps video output (not used in Mission 7223), (2) a video peak detector, and (3) the four narrow-band filter detectors.

F. Video Processors

1. Wideband Video Amplifier

The delay line pulse stretcher is adjustable such that the receiver wideband video output pulses can be stretched from 0.5 to 5.0 microseconds. A 1 Mcps reference tone (sine wave) is added to the fan beam receiver channel wideband video for the purpose of monitoring wow and flutter of the wideband orbital recorder (not used). The frequency tolerance of the oscillator is ± 15 ppm at 25°C. The maximum frequency deviation is ± 30 ppm from 0 to 145°F.

2. Video Peak Detector

The peak detector employs an equivalent RC circuit that has a short charge time and a long discharge time constant. It depends on a minimum charging time of 7.2 μ s during a 2 millisecond period to perform its

~~SECRET-SPECIAL HANDLING~~

~~SECRET-SPICIAL HANDLER~~

AWO1884

- 8 -

its function properly. This corresponds to 16 pulses of 0.45 μ s duration each. The pulses charge the capacitor to within 1% of its final value. The resistance in the discharge path is sufficiently great to hold the capacitor charge to within 1% of its maximum value for a minimum of 3 Ms, the time required to be within the transient response of the peak detector telemetry channels. The 25 db output voltage range of the peak detector will be calibrated in terms of the 40 db RF input dynamic range.

The peak detector circuit is capable of resolving carrier frequency bands within ± 5 Mcps, except in the case where a high-level signal is adjacent to a low-level signal. The peak detector output will appear as a $\sin x$ over x function as the receiver sweeps through the high-level signal, and its lower order side lobes may cover over the low-level adjacent channel signal thereby making the latter undetectable.

3. Narrowband Filter Detectors

Since the wideband video signal is not being telemetered, another method is used whereby certain frequency components are filtered from the video amplifier output and "read out" for the purpose of identifying the signals received. The signal of interest is known to contain very stable 96.0 Kcps and/or 192.0 Kcps frequencies, and does not contain modulation frequencies below 300 cps. For example, a spectrum analysis of the 12-channel signal of interest appearing in the receiver video amplifier output would contain a 96 Kcps channel rate frequency, and the second harmonic thereof (192 Kcps). The nearest frequencies to the channel frequency and its harmonic should be 95.7, 96.3, 191.7 and 192.3 Kcps. The pencil and fan beam receivers each employ 4 sharply tuned filters to analyze the frequency content of their respective video

~~SECRET-SPICIAL HANDLER~~

signals. Two of the filters (96.0 Kcps and 192.0 Kcps) are tuned to the channel-rate frequencies of the signals of interest and the other two (95.8 and 192.8 Kcps) are tuned to frequencies not contained in the signal. Thus every signal received may be analyzed for frequency content by noting the relative amplitude levels appearing in each of the four filters, and a judgement can be made as to whether or not it has the characteristics of the signal of interest; i.e. if the energy appearing at the 96.0 Kcps filter is many times greater than energy appearing in the 95.8 Kcps filter, and/or the energy appearing at the 192.0 Kcps filter is many times greater than the energy in the 191.8 Kcps filter, the signal is said to have been identified.

The video signal is passed through a limiter, which eliminates the upper 15 db range of the video amplifier, and is presented to four parallel narrow-band filter detectors. Each narrow-band device includes a mixer, stable local oscillator and 150 +50 cps band-pass filter. Each local oscillator is tuned to a frequency that is 150 cps above or below the desired filter frequencies. It is necessary to "down convert" the 96.0, 192.0, 95.8, and 191.8, Kcps frequencies to a lower frequency such as 150 cps in order to conserve information bandwidth.

The four crystal oscillator frequencies are held to within +150 ppm over the 0 to 145°F temperature range.

The 150 cps active filter bandwidth is 134 cps at -3 db and 242 cps at -30 db.

In the pencil beam receiver each of the four 150 cps filter output frequencies modulates a voltage-controlled oscillator whose output is directed to the telemeter system. In the fan beam receiver only the 150 cps analog signals proportional to the 96 and 192 Kcps "yes" frequencies are made available for analysis. The "no" or "not" frequencies

~~SECRET~~-SPECIAL HANDLING

AW01884

- 10 -

are combined via a comparator circuit into a four-level digital signal. The "yes" signal amplitudes are compared with the "no" signal amplitudes resulting in four possible conditions as described below in Part H. The four-level signal modulates a voltage-controlled oscillator and thereby serves as a "recognition" signal for the fan beam channel. It is important to note that this signal should not be relied upon entirely as an indicator for whether or not to monitor the "yes" signals from the fan beam channel. The digital level indicates recognition if either or both of the "yes" energy levels are 15 db or greater than the "no" levels. If the received signal power is marginal (near -97 dbm) it is possible that the energy in a "yes" filter could be considerably greater than the energy in its "negative" counterpart, but not 15 db. Thus there would be no recognition indication; however, the received signal would be the one of interest.

Also a two-level recognition signal is developed as a byproduct of the four-level signal. It therefore has the same limitations as the four-level signal, and it provides a recognition indication only if the video amplifier S/N exceeds about 4 db and either of the two 15 db S/N level requirements is exceeded. The two-level signal is routed to the payload commutator, and to the wideband recorder to serve as a "start signal". The wideband recorder will not be used in Mission 7223.

G. Receiver Outputs Available For Analysis

Signal outputs recorded during the payload system operation period and later replayed via the telemetry link for analysis are as follows:

1. Payload commutator - provides payload temperature and power supply voltage data; vehicle time; radio frequency monitor, fan beam channel recognition indicator (2 level), and on-orbit calibrator on-off monitor.

~~SECRET~~-SPECIAL HANDLING

~~SECRET~~-SPECIAL HANDLING

AW01884

- 11 -

2. Pencil Beam Channel - 5 analog outputs, one RF peak detector, and four 150 \pm 50 cps filter outputs whose energies are proportional to the amplitude of the 96.0, 95.8, 192.0 and 191.8 Kcps frequencies contained in the received signal video.
3. Fan Beam Channel - 3 analog outputs and one four-level digital output. The analog outputs are the fan beam RF peak detector and two 150 \pm 50 cps filters whose outputs are representative of the 96.0 and 192.0 Kcps energy detected in the fan receiver video. The four-level digital output serves as a recognition indicator for the fan channel. It is derived from threshold and comparator circuitry which logically examines the video signal threshold and compares the amplitude ratios of the four 150 cps filters identical to those used in the pencil channel. The four-level digital signal was developed in lieu of using the analog outputs of the 95.8 and 191.8 Kcps detectors because: (1) only one telemetry voltage-controlled oscillator is required to convey the digital signal while two would be required for the analog signals, (2) a recognition signal was required to start a 1 Mcps recorder (not used for this mission).

H. Recognition Signal Outputs

Two recognition signal outputs, one two-level signal, and one four-level signal are available for analysis from the fan beam channel only. The four-level signal is a logical signal, developed as mentioned above in paragraph G, which relates the following information about the signal received:

1. Level 1 - negative recognition (0.0 V)
2. Levels 2, 3 and 4 respectively: the 150 cps energy from the 96.0 Kcps detector is greater than 15 db above the 95.8 Kcps detector

~~SECRET~~ SPECIAL HANDLING

~~SECRET~~-SPECIAL HANDLING

AWO1984

- 12 -

energy (1.65 V); the 150 cps energy from the 192.0 Kcps detector is greater than 15 db above the 191.8 Kcps detector energy (3.3 V); both of the last two statements are true (4.95 V).

The two-level signal is developed from the four-level logic. It provides the following information:

1. 0-VDC level - negative recognition.
2. 4.5 V peak, 100 MS pulse - implies that both the peak RF signal power at the fan receiver input terminals is equal to or greater than -93 dbm, and the 96 Kcps detector output is 15 db greater than 95.8 Kcps detector output and/or the 192 Kcps detector output is 15 db greater than the 191.8 Kcps detector output. The two-level recognizer is disabled during the on-orbit calibrator period.

I. On-Orbit Calibrator

An internal payload calibrator simultaneously applies signals to both receiver RF amplifiers to verify normal payload performance. The characteristics of the calibration signal are:

1. Power: -87 ± 3 dbm.
2. Freq.: 1575 ± 2 Mcps.
3. Duty Cycle: On for $\frac{1}{2}$ second every 32 seconds in synchronization with the vehicle clock and the receiver sweep generator.
4. Modulation Signals: On odd-integer multiples of 32 seconds the RF carrier is pulse modulated at a 96 Kcps rate thereby causing 150 cps energy to appear in the 96.0 and 192.0 Kcps detector output circuits and no energy in the "not" filter outputs. On even-integer multiples of 32 seconds the RF carrier is pulsed by a 96 Kcps wave train which is gated on and off at a 200 cps rate thus causing

~~SECRET~~-SPECIAL HANDLING

energy to appear in all filter circuits. The 150 cps energy appearing in the 96 Kcps and 95.8 Kcps detector is 3 db and 10 db respectively below that for a continuous 96 Kcps wave train. The same relative ratios are true for the 192 Kcps component whose amplitude is about 1 db less than the 96 Kcps component.

J. Voltage-Controlled Oscillators

Standard IRIG VCO's are used as FM subcarriers to convey the pencil beam and fan beam channel output signals. The channel assignments are listed:

<u>VCO Channel</u>	<u>Pencil Beam Channel Output</u>	<u>Fan Beam Channel Output</u>
10	Peak detector	Payload Commutator*
11	150 cps (191.8 Kcps)	Peak Detector
12	150 cps (95.8 Kcps)	Four-level Comparator
13	150 cps (192.0 Kcps)	150 cps (192.0 Kcps)
14	150 cps (96.0 Kcps)	150 cps (96.0 Kcps)

*Conveys pencil and fan beam receiver data.

The five VCO outputs from the pencil beam channel (pencil beam composite video) are summed and directed to track one of the 25 Kcps/100 Kcps recorder-reproducer. The five VCO outputs from the fan channel are combined with a stable 25 Kcps reference tone (fan beam composite video) and applied to the second track of the payload recorder-reproducer.

The 150 cps analog signals which drive the VCO's directly, are amplitude limited to a 25 db range in order to be compatible with the input dynamic range of the VCO's.

K. Blanking Signals And Band Markers

Blanking Signals are generated and inserted as required in the video processor to blank the fan and pencil channel output signals during the 0.2

~~SECRET~~-SPECIAL HANDLING

AWO1884

- 14 -

sec. flyback portion of the receiver sweep. Also 40 millisecond pulses are added to all processed output signals which serve as amplitude calibration markers. The leading and trailing edges of these markers provide time reference points for receiver sweep start and stop. The band markers are specifically identified in Appendix II.

IV. COMPOSITE SYSTEM

Orbital System Description And Operation.

A block diagram of the pertinent composite orbital system showing the payload receivers, antennas, commutators, clock, tape recorder, and telemetry system is shown in Appendix III.

The payload receivers, commutator and tape recorder are turned on simultaneously by preprogrammed punched-tape commands for a 24 minute read-in period. The composite pencil beam video and the composite fan beam video are recorded simultaneously on tape recorder tracks 1 and 2 respectively (300 cps to 25 Kcps response). Vehicle timing and payload response and status data are commutated and modulate a channel 10 VCO which is multiplexed in the composite fan beam video signal.

Another preprogrammed command and/or real time command initiates a 6 minute read-out period whereupon the recorder data are relayed, at four times the read-in speed, via two FM transmitters to the tracking station receivers.

In addition, real-time timing outputs and vehicle attitude information are commutated by a real time "housekeeping" commutator and telemetered via a third vehicle FM link.

V. DATA ANALYSIS

A. Signal Identification, Measurement, And Video S/N Analysis.

To decide whether or not the received signal has characteristics identical to the one of interest, it is necessary to compare simultaneously

~~SECRET~~-SPECIAL HANDLING

the amplitudes of each of the 150 cps signals contained in a given receiver channel composite video signal, i.e., for example, in the pencil channel note the simultaneous S/N's of the peak detector and the four narrow-band detector outputs. The bursts of energy from the detector outputs are delayed about 15 Ms from the peak detector output because of the rise time of the 150 cps filters. The center of the burst of peak detector energy relative to its time position between the band start and end markers determines the received signal frequency. The peak detector S/N is directly proportional to the received signal RF power. The peak detector S/N measurement may be used as a guide to decide whether or not to analyze closely the narrow filter outputs. Received signals whose peak powers are greater than, say, -80 dbm, are not likely to be the signal of interest.

The S/N ratios of the four narrow-band detector outputs should be carefully analyzed since they provide the greatest weighting for signal identification. To understand the implication of the narrow-band filter it is necessary to consider the characteristics of the video processor and its associated interface. Refer to the receiver block diagram in Appendix I. The wideband video signal input to the narrow-band detector is limited to 10 db maximum and the narrow-band output is confined to a nominal 25 db dynamic range. It is possible to predict the S/N appearing at the output of a given narrow-band detector using the following expression:

$$\begin{array}{rcccl}
 \text{Narrow Band} & & \text{Video} & & \text{C/A} \\
 \text{Detector Output S/N} & = & \text{S/N} & + & + \text{NIF} \\
 \text{(db)} & & \text{(db)} & & \text{(db)}
 \end{array}$$

Video S/N (db) is the signal-to-noise, expressed in db, at the input to the narrow-band detector.

C is the amplitude in volts of a frequency of interest contained in the receiver video, e.g. 96 Kcps.

~~SECRET-SPECIAL HANDLING~~

AW01884

A is the amplitude in volts of a PPM pulse train contained in the receiver video.

C/A (db) is $20 \log C/A$ and varies as a function of pulse width, duty factor and percentage channel modulation.

NIF (db) is the signal-to-noise improvement factor (in db) gained by band-passing only 100 cps out of a 1.65 M cps video signal.

For illustration consider a 12-channel signal with the following characteristics: pulse width 0.7 μ sec, sync channel modulation 10%, data channel modulation 40%. To determine the narrow-band detector output signal-to-noise ratio for a 96 K cps component proceed as follows:

$$\begin{array}{l} \text{Narrow Band} \\ \text{Detector output} \\ \text{S/N (db)} \end{array} = \begin{array}{l} \text{Video} \\ \text{S/N (db)} \end{array} + (-19.6 \text{ db}) + 37 \text{ db} = \begin{array}{l} \text{Video} \\ \text{S/N (db)} \end{array} + 17.4 \text{ db}$$

Note: The 96 K cps component is about 19.6 db below the video peak signal.

The NIF (db) for a 150 ± 50 cps filter output is about 37 db.

If the resultant expression is evaluated for a video S/N range of 0 to 10 db the narrow-band detector output range for this particular signal is 17.4 db to 25.0 db, i.e. signals 7.6 db above the nominal receiver sensitivity of -97 dbm would be limited to ^{now 40 db} 25 db because of the filter output range restriction, and signals 10 db or greater than -97 dbm would also be limited because of the ^{*} 10 db limit imposed on the narrow-band detector input.

The latter limitation is of no significance in this example since the output range limitation prevailed first, but may take precedence in other situations.

In this particular example, the input signal power can be less than -97 dbm, thereby resulting in a negative wide band video S/N, and yet provide a positive narrow-band detector output S/N ratio as large as 17.4 db.

**not true
practically speaking because
(1) a positive
signal to noise
improvement
is achieved near, at, and above +10 dbm*

- (a) the noise is clipped off the top side of the pulse
- (b) the noise is not available for the signal power is not available

~~SECRET-SPECIAL HANDLING~~

~~SECRET-SPECIAL HANDLER~~

AW01884

- 17 -

Consider, for comparison, a 12-channel signal identical to the previous except that all channels are present but not modulated. C/A is about -17.4 db therefore the narrow-band-output range would vary from 19.6 to 25 db if only positive wide-band video S/N ratios were considered.

Consider another example for a 12-channel signal identical to the previous except that all data channels are modulated at 80%. C/A is about -31 db thus the narrow-band output range would vary from 6 to 16 db if only positive wide-band video S/N ratios were considered.

In summarizing it is apparent from the preceding equation and the associated examples that the output range of the narrow-band detectors is restricted to a maximum dynamic swing of 10 db which may occur anywhere in the 25 db output range (.28 to 5.0 volts). This conclusion is based on positive video S/N ratios only. The relative position of the 10 db band within the 25 db range is determined by the signal power, pulse width duty factor and percentage channel modulation, and the narrow-band filter detector noise improvement factor. The 10 db band is widened when negative video S/N ratios are considered, the degree of which is directly related to the capability of the narrow filter to remove the desired signal from the video noise.

Knowing the general capability of the video processor and recalling the signal identification criterion established in III-F3 it is interesting to note that any of the following combinations, referred to as "cases", of S/N ratios could be due to a valid signal. Only the 96 K cps "yes" filter and the 95.8 K cps "no" filter are considered in this illustration.

~~SECRET-SPECIAL HANDLER~~

Possible Filter Combinations Due To Valid Signal

<u>Case</u>	<u>"Yes" Filter Output S/N Range</u>	<u>"No" Filter Output S/N Range</u>
1	1 to 1 $\frac{1}{2}$ db	0 db
2	15 to 25 db	0 to 10 db
3	filter output saturated (25 db); or limited to a 10 db band within the 25 db range	10 db to saturation; or limited to a 10 db band within the 25 db range

Case 1 indicates that the received signal may be defined as valid with as little as 1 db S/N appearing in the "yes" filter. Obviously the confidence factor improves directly as the yes-to-no ratio increases. Case 2 shows the range of optimum receiver performance. The yes-to-no ratio of 15 db used in the fan channel recognition circuitry should not necessarily be considered as the ultimate signal identification ratio when evaluating the pencil channel analog signals.

Case 3 is theoretically impossible since there is no 200 cps energy in the modulation signal, and no 95.8 Kcps carrier sidebands exist; but practically it should be considered, especially since the dynamic range of the narrow-band filters could be limited to a 0 to 10 db S/N band over the 25 db VCO input amplitude dynamic range. Depending on the amount of 95.8 Kcps noise present, particularly in the fan channel which views a relatively large geographical area, it is possible to have enough energy appear in the 95.8 Kcps filter output to affect the valid signal confidence factor.

A detailed analysis of the fan beam channel data will be more difficult relative to the pencil beam channel in regard to determining whether or not the received signal was valid, because only two analog "yes" signals and a four-level digital recognition signal are available. The digital logic responds as indicated in Part III-H. This signal would indicate positive

~~SECRET~~ SPECIAL HANDLING

AWOL884

- 19 -

recognition for Case 2 only. It would never indicate recognition for Case 1 and may or may not indicate recognition for Case 3 depending on the relative yes-to-no ratios.

B. Data Correlation Between Receiver Channels

It is desirable to correlate signals appearing in the pencil channel with those in the fan channel particularly since the pencil channel refines the geographic location.

There is a time lapse between when the signal appears in the fan channel and reappears in the pencil channel which may vary from 20 to 310 seconds. Thus it is necessary to slide the data from the pencil channel backward along the time scale and correlate them with signals in the fan channel which have identical carrier frequencies.

C. Duration of Signal Intercept

Pencil Beam Channel - The pencil beam antenna intercepts any particular ground emitter signal for a maximum period of 5.2 seconds, assuming the vehicle speed to be 4 nm/sec. Therefore a maximum of 2 successive bursts of energy, spaced 2.0 seconds apart, will appear in the receiver video. One burst occurs each time the receiver sweeps through the RF carrier (receiver sweep rate - 9 Ms/Mcps) and each burst lasts about 29 Ms (effective receiver bandwidth - 3.3 Mcps.)

Fan Beam Channel - Theoretically the fan beam antenna could intercept a ground emitter signal for 290 seconds, thus 145 consecutive bursts of energy would appear in the fan beam receiver video. The burst duration and the spacing between intercepts is the same as for the pencil beam channel.

D. Receiver Link Calculations

A comparison of the link calculations for the fan beam and pencil beam receiver channels shows that for signal identification in the fan receiver

~~SECRET~~ SPECIAL HANDLING

1 AUGUST, 2015

~~SECRET~~ SPECIAL HANDLER

AW01884

- 21 -

the clock 4 sec level is also read out, thereby providing evidence that the vehicle clock is functioning, and a course reference to check the timing accuracy of the H-timer data.

VI. CALIPRATION DATA

System level calibration data will be provided in a supplement to this document.

~~SECRET~~ SPECIAL HANDLER

APPENDIX I
~~SPECIAL HANDLING~~
RECEIVER BLOCK DIAGRAM

~~SPECIAL HANDLING~~

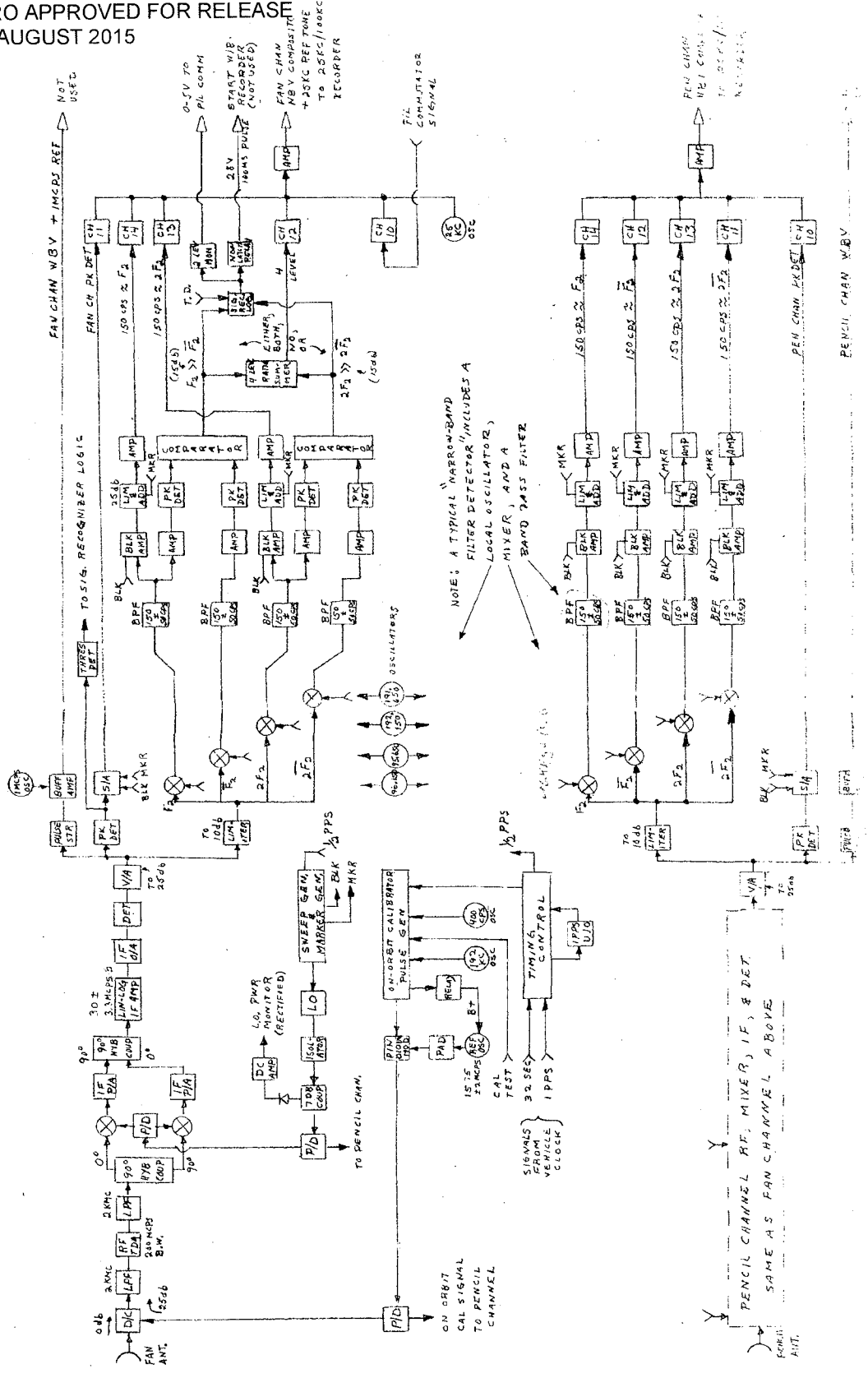

PENCIL CHAN W.B.V.

PENCIL CHANNEL REF. MIXER, IF, & DET.
SAME AS FAN CHANNEL ABOVE.

APPENDIX I ABBREVIATIONS

D/C	Directional Coupler
P/D	Power Divider
LPF	Low Pass Filter
RF TDA	Radio Frequency Tunnel Diode Amplifier
HYB COUP	Hybrid Coupler
IF P/A	Intermediate Frequency Pre Amplifier
IF O/A	IF Output Amplifier
DET	Detector
V/A	Video Amplifier
BLK	Blanking Signal
MKR	Marker Signal (Band End and Band Start)
UJO	Unijunction Transistor Oscillator
BW	Band Width
STR	Stretcher
S/A	Summing Amplifier
F_2	96.0 KC Energy Present in Video Signal
$\overline{F_2}$	95.8 KC Energy Present in Video Signal
$2F_2$	192.0 KC Energy Present in Video Signal
$\overline{2F_2}$	191.8 KC Energy Present in Video Signal
NBV	Narrow-Band Video
WBV	Wide-Band Video

APPENDIX II
BAND MARKER
IDENTIFICATION

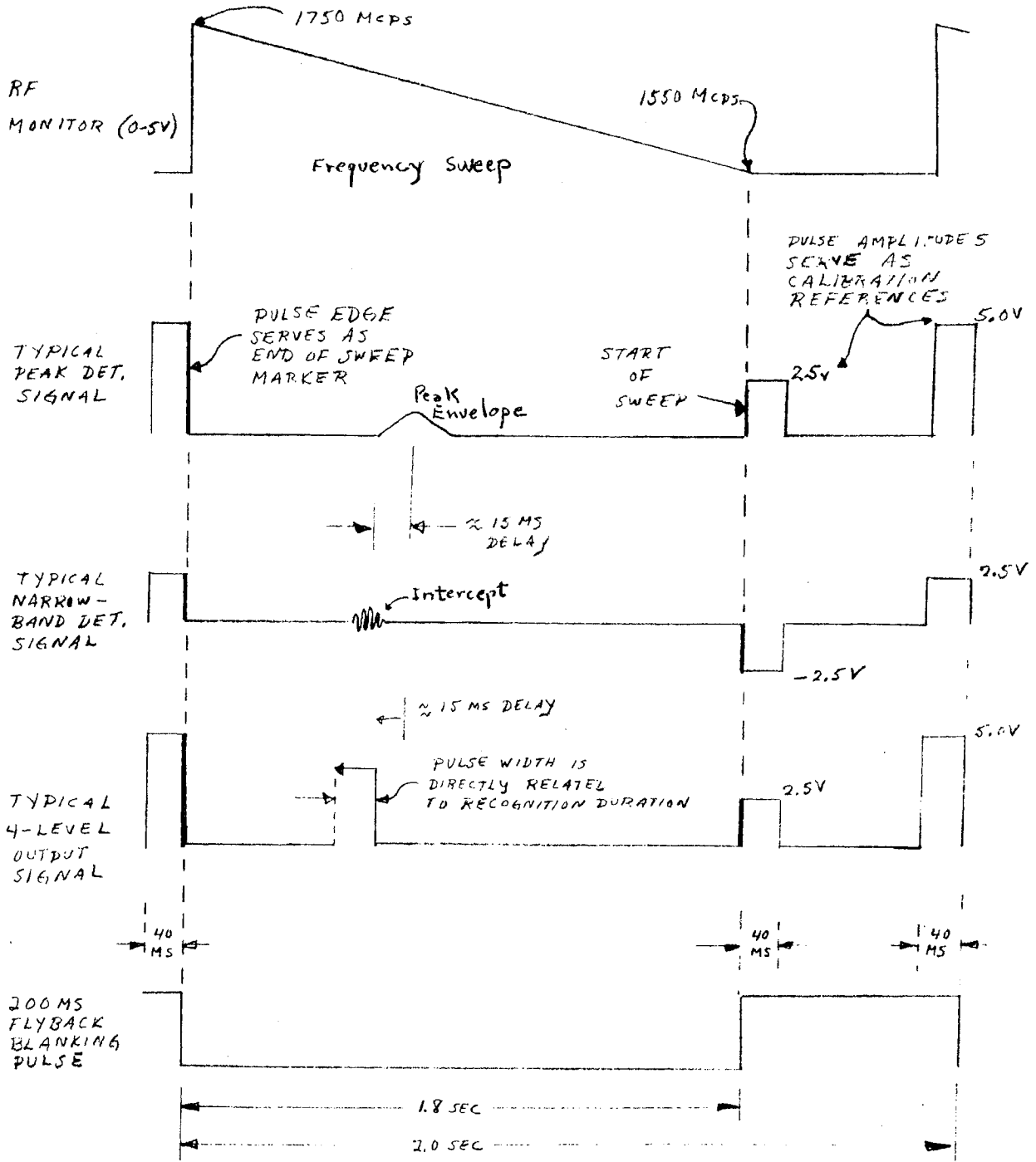

(+) TIME DIRECTIONS:

- VEH. TAPE RECORDER READ-OUT →
- VEH. TAPE RECORDER READ-IN ←

P/L-VEHICLE SYSTEM BLOCK DIAGRAM

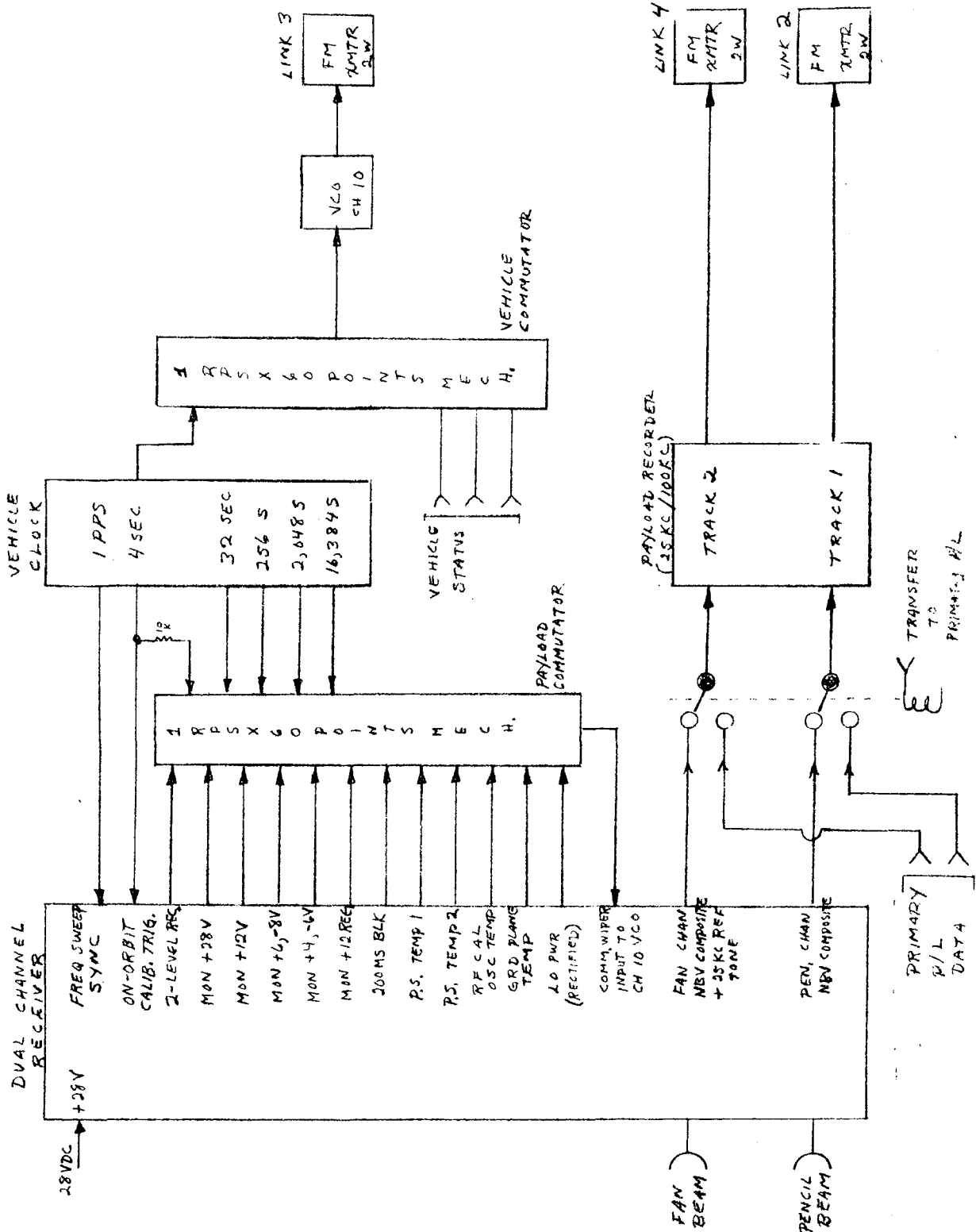

~~SECRET-SPECIAL HANDLING~~

AW01884

- 26 -

APPENDIX IV

PAYLOAD COMMUTATOR INSTRUMENTATION SCHEDULE

Comm. Chan. No.	O.T.E. No.	Monitor (Voltage Level)	Comm. Chan. No.	O.T.E. No.	Monitor (Voltage Level)
1	1	Freq. (1 to 5 V)	31	1	Freq.
2	2	Fan Recog. (0; 4.5 V)	32	2	Recog.
3	3	+28 V Reg. (4.6V)	33	9	Pwr.Supp. Temp.#1 (.3 to 5V)
4	4	On-orbit Cal. (0; 4.5 V)	34	4	On-orbit Calib.
5		Vehicle clock - 4 sec.	35		Spare
6	1	Freq.	36	1	Freq.
7	2	Recog.	37	2	Recog.
8	5	+4, & -6V Pwr.Supp.(2.0V)	38	10	+12 Reg.Pwr.Supp. (4.5V)
9		Cal Z	39		Veh. Clock -2,048 sec.
10	14	200 MS Blanking (Flyback)	40	14	200 MS Blanking
11	1	Freq.	41	1	Freq.
12	2	Recog.	42	2	Recog.
13	6	+12 V Pwr.Supp. (4.5 V)	43	11	Pwr. Supp.Temp.#2 (.3 to 5V)
14		Veh. Clock -32 sec.	44		Spare
15		Spare	45		Veh. Clock - 4 sec.
16	1	Freq.	46	1	Freq.
17	2	Recog.	47	2	Recog.
18		Rectified LO RF Pwr.(2.5V)	48	12	On-orbit Cal Osc.Temp. (.3 to 5V)
19	4	On-orbit Calib.	49	4	On-orbit Calib.
20		Spare	50		Spare
21	1	Freq.	51	1	Freq.
22	2	Recog.	52	2	Recog.
23	8	+6, & -8V Pwr.Supp. (4.5V)	53	13	Grd.plane Temp. (.3 to 5V)
24	14	200 MS Blanking	54		Veh. Clock - 16,384 sec.
25		Veh. Clock - 4 sec.	55	14	200 MS Blanking
26	1	Freq.	56	1	Freq.
27	2	Recog.	57	2	Recog.
28		Veh. Clock - 256 sec.	58		Sync
29		Cal +	59		Sync
30		Cal 1/2	60		Sync

~~SECRET-SPECIAL HANDLING~~

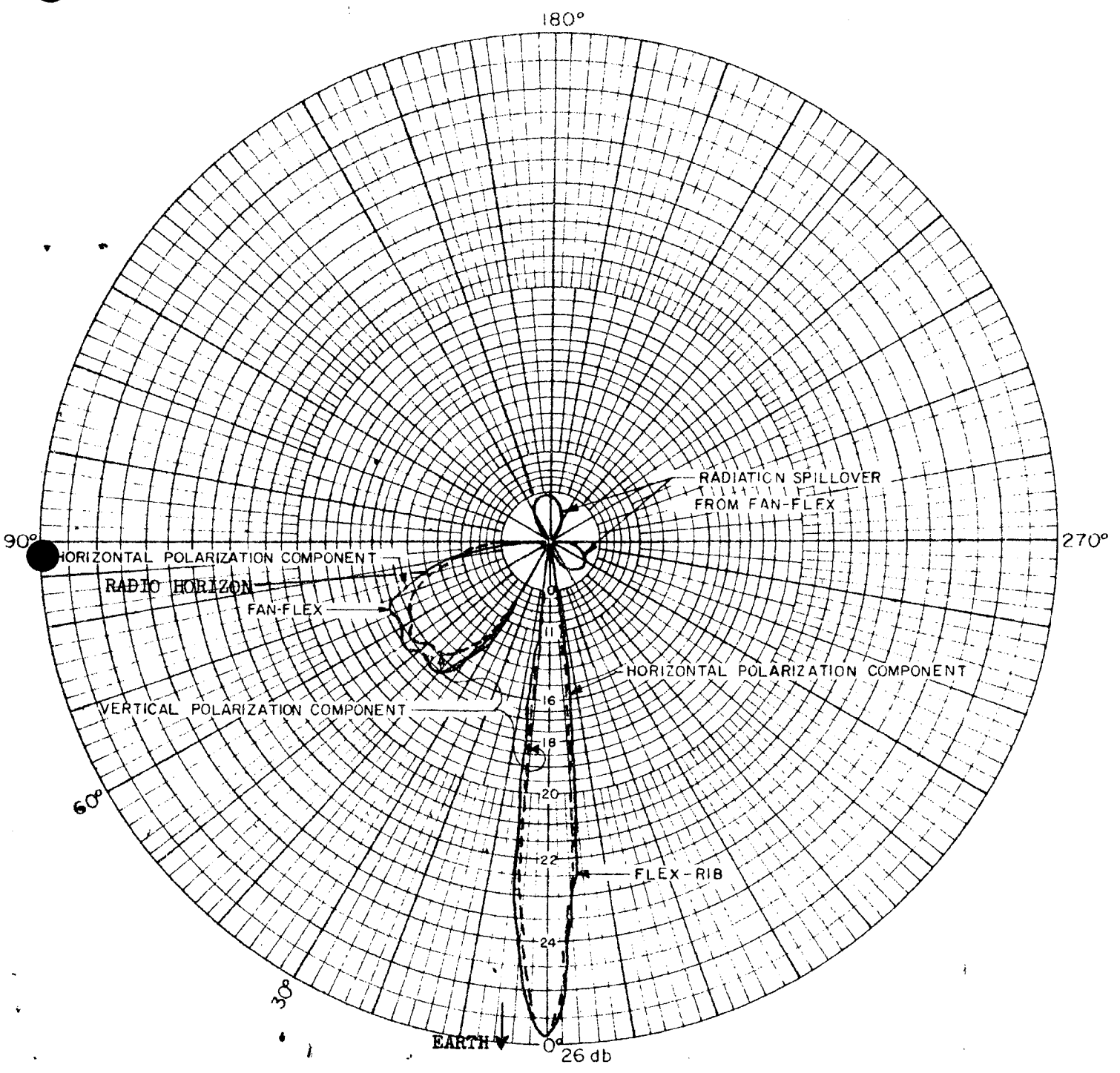
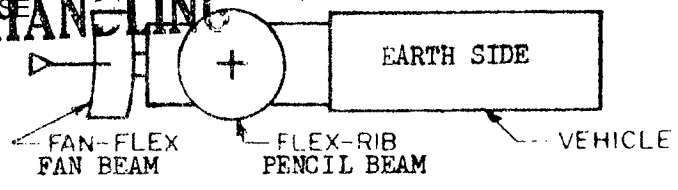

FAN-FLEX AND FLEX-RIB REFLECTORS
 FED WITH A
 CONICAL SPIRAL FEED
 ON THE AGENA VEHICLE
 8-9-65

~~SECRET-SPECIAL HANDLING~~

28

AW01884
ADDENDUM

27 October 1965

SQUARE TWENTY
SYSTEM CALIBRATION DATA
MISSION 7225

THIS DOCUMENT IS A SUPPLEMENT TO AW01884, 12
AUGUST 1965, "SQUARE TWENTY SYSTEM TECHNICAL
DESCRIPTION"

Prepared by *L. J. Doll*
L. J. Doll

Approved by *William M. Harris*
W. M. Harris

Prepared by *L. R. Whitlock*
L. R. Whitlock

~~SECRET-SPECIAL HANDLING~~

~~SECRET-SPECIAL HANDLING~~

7225 CALIBRATION DATA PARTICULARS

I. CALIBRATION DATA CONSTANTS

A. Temp: 75°F unless noted.

B. Low pass filters used to generate CEC records from which calibration data was reduced:

<u>SCD</u>	<u>LPF_{FAN}</u>	<u>LPF_{PEN}</u>
10	125 cps	160 cps
11	160 cps	160 cps
12	160 cps	160 cps
13	160 cps	160 cps
14	225 cps	225 cps

C. Values for calibration markers used to obtain Cal data from CEC records.

Values were measured at receiver test points.

<u>Receiver Outputs</u>	<u>Band Start Markers</u>	<u>Band End Markers</u>
PK DET _p	+2.4	4.85
F _{2PEN}	-2.45	2.4
\bar{F} _{2PEN}	-2.4	2.3
2F _{2PEN}	-2.5	2.4
2 \bar{F} _{2PEN}	-2.4	2.3
PK DET _{FAN}	2.5	5.0
F _{2FAN}	-2.4	+2.5
2F _{2FAN}	+2.4	2.6
4 level Detector	+2.4	+4.8

~~SECRET-SPECIAL HANDLING~~

~~SECRET-SPECIAL HANDLING~~

AW01884 Addendum

30

II. SCOPE OF CALIBRATION DATA

All calibration data represents receiver performance via the entire orbital system.

III. ON-ORBIT CALIBRATOR

The internal Radio Frequency Calibrator (RFC) power response was measured and superimposed on the power response graphs. The Input Signal power required to equal the RFC power response of the particular detector is shown. The Input Signal constants, which are applicable, are listed on the graphs.

IV. FAN BEAM CHANNEL CALIBRATION DATA

In general the calibration curves for the pencil receiver will suffice for the fan receiver. If a more precise fan beam receiver calibration data accuracy is desired, see the tabulated chart which shows the "fine" differences between the fan and pencil receiver response to input signal power and the on-orbit calibrator.

~~SECRET-SPECIAL HANDLING~~

~~SECRET-SPECIAL HANDLING~~

AW 01884

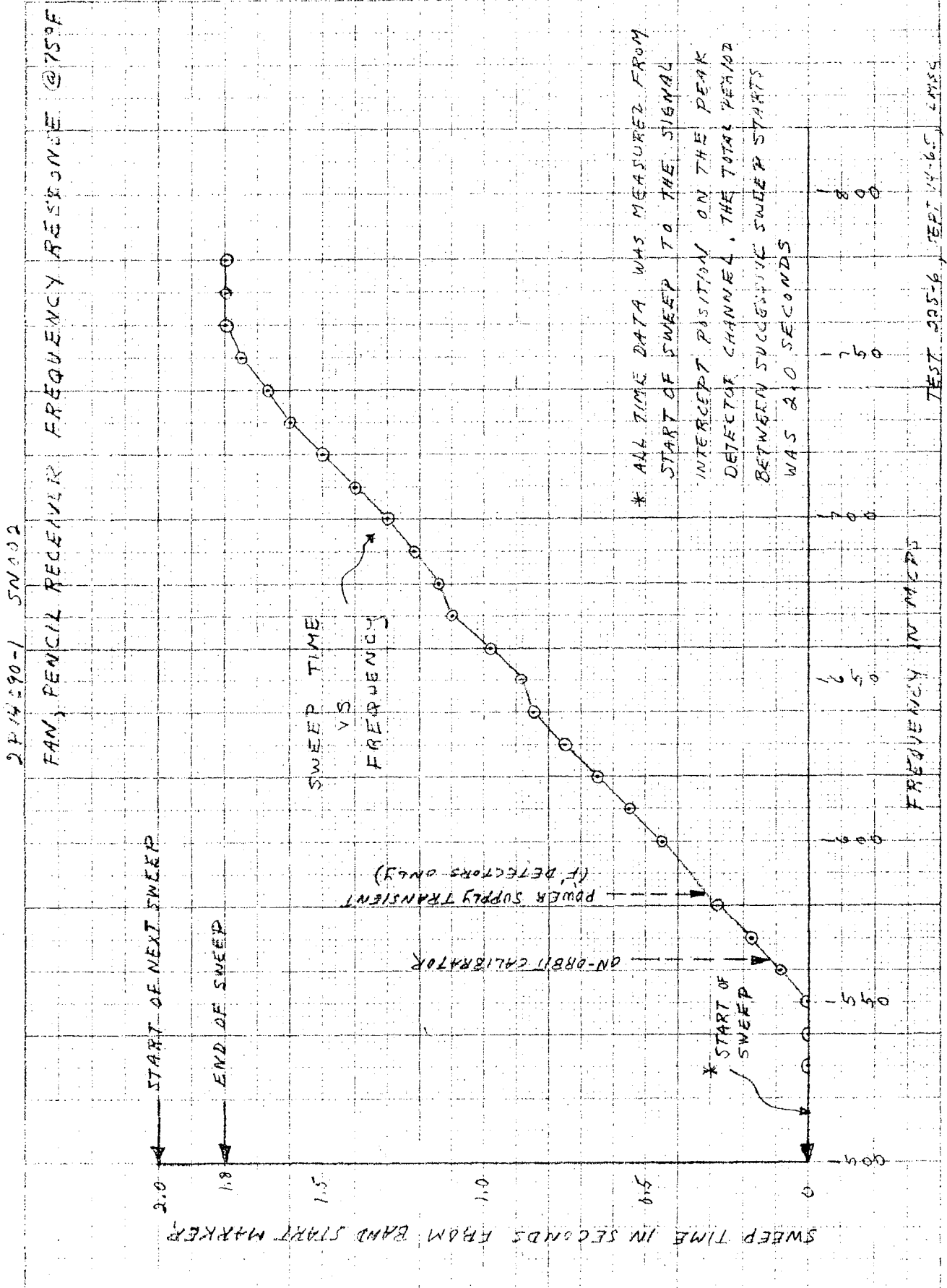

~~SECRET-SPECIAL HANDLING~~

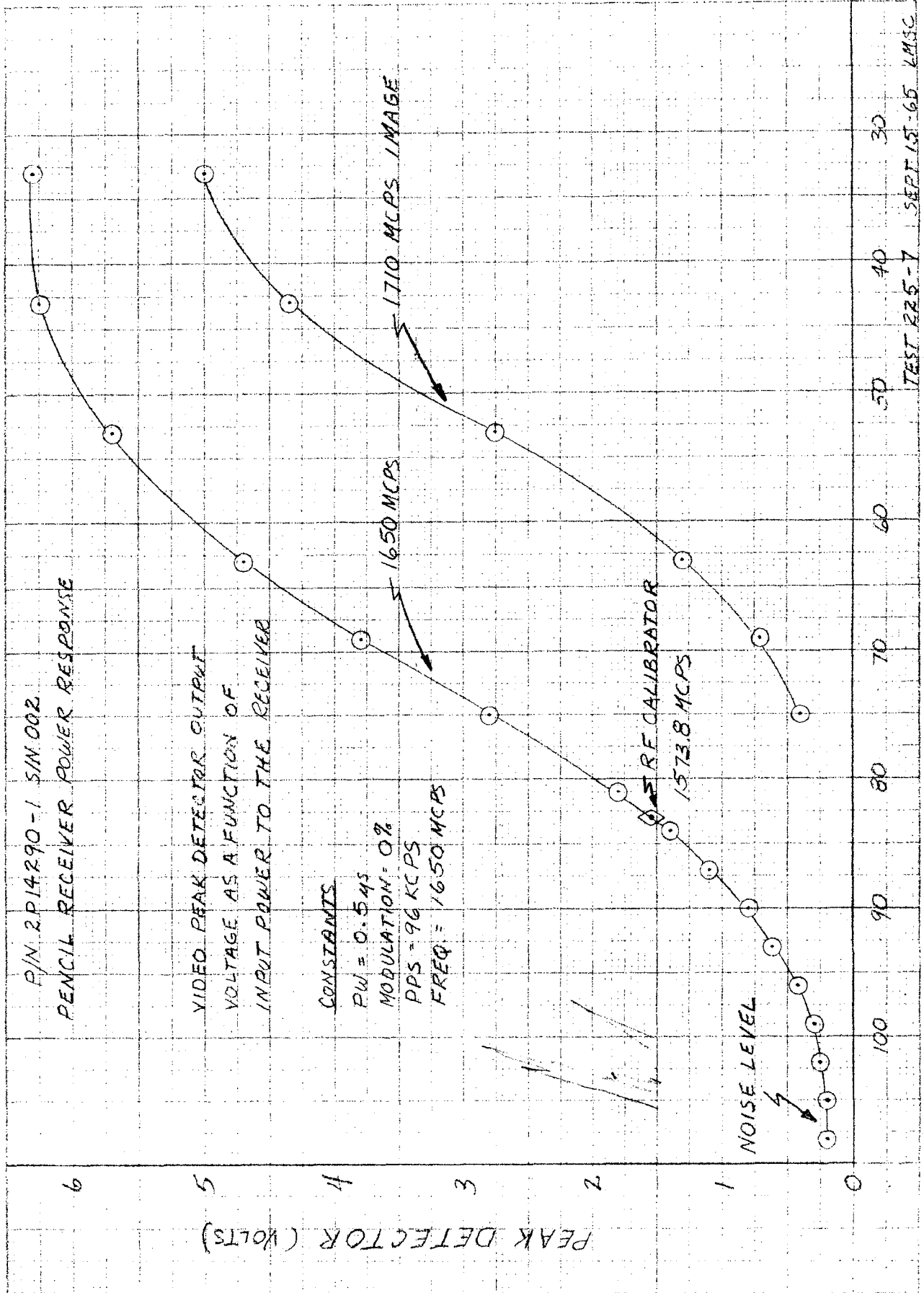

INPUT POWER (-dbm)

TEST 225-7 SEPT 15-65 KMSC

~~SECRET~~ SPECIAL HANDLING AN 01884

P/N. 2P14290-1 SIN 002
PENCIL RECEIVER POWER RESPONSE

E DETECTOR OUTPUT VOLTAGE AS A FUNCTION
OF INPUT POWER TO THE RECEIVER

CONSTANTS

PW = 0.54S
MODULATION = 0%
PPS = 96 KCPS
FREQ. = 16.50 MCPS

RF CALIBRATOR 1573.8 MCPS

1710 MCPS IMAGE

1650 MCPS

NOISE LEVEL

F DETECTOR OUTPUT (VOLTS P-P)

INPUT POWER (-dbm)

TEST 225-7 SEPT 15-65 LMSC

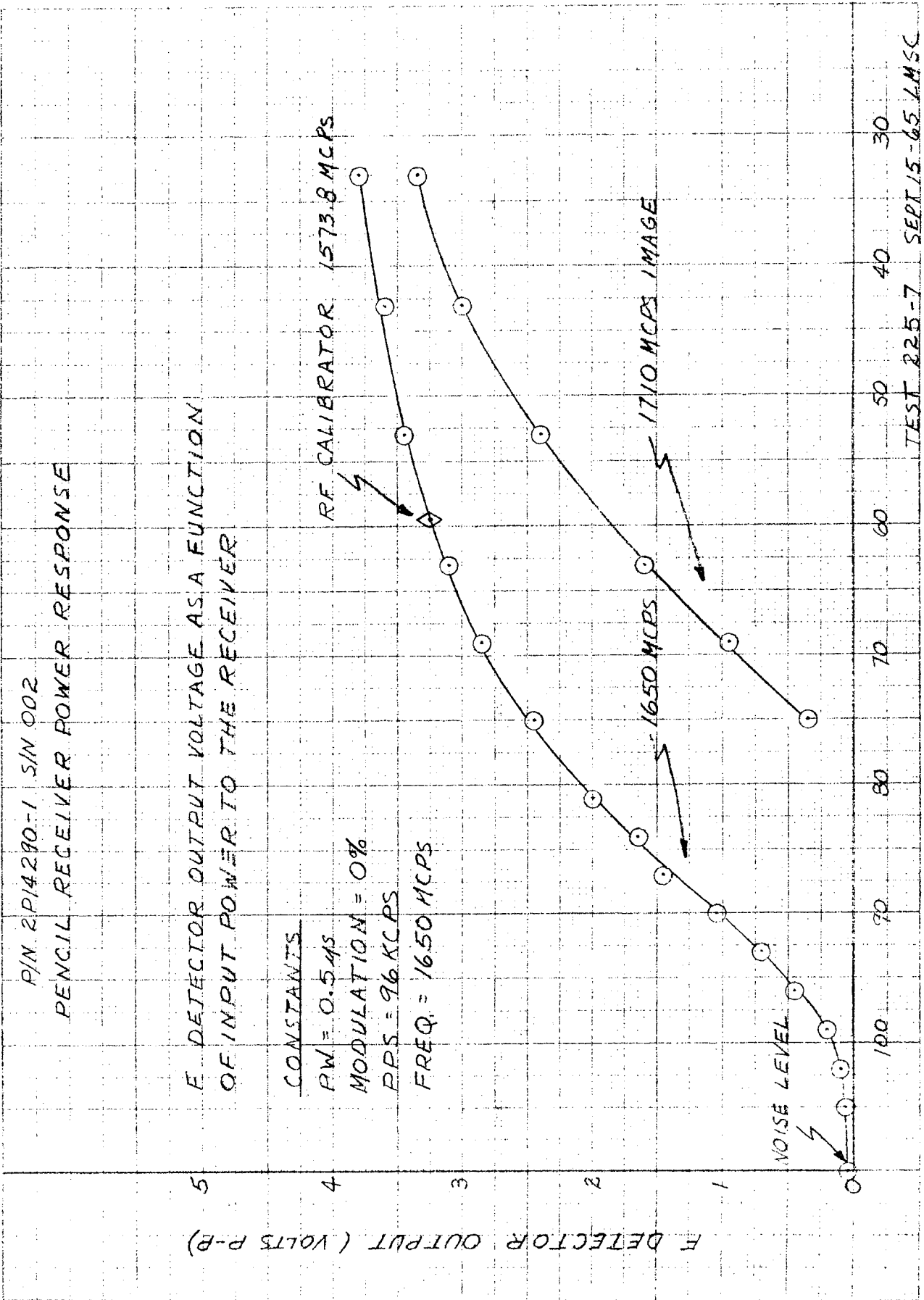

~~SECRET~~ SPECIAL HANDLING

~~SECRET-SPECIAL HANDLING~~

AN 01884

R/N 2P14290-1 SIM 002
PENCIL RECEIVER POWER RESPONSE

F DETECTOR OUTPUT VOLTAGE AS A FUNCTION
OF INPUT POWER TO THE RECEIVER

CONSTANTS

PW = 0.5 MS

MODULATION = 0%

PRS = 9% KEPS CHOPPED AT 200 CPS

FREQ = 1650 MCPS

RF CALIBRATOR

1573.8 MCPS

1650 MCPS

1710 MCPS / MARG

NOISE LEVEL

F DETECTOR OUTPUT (VOLTS P-P)

INPUT POWER (-dbm)

TEST 225-17 SEPT 15-65 AMSC

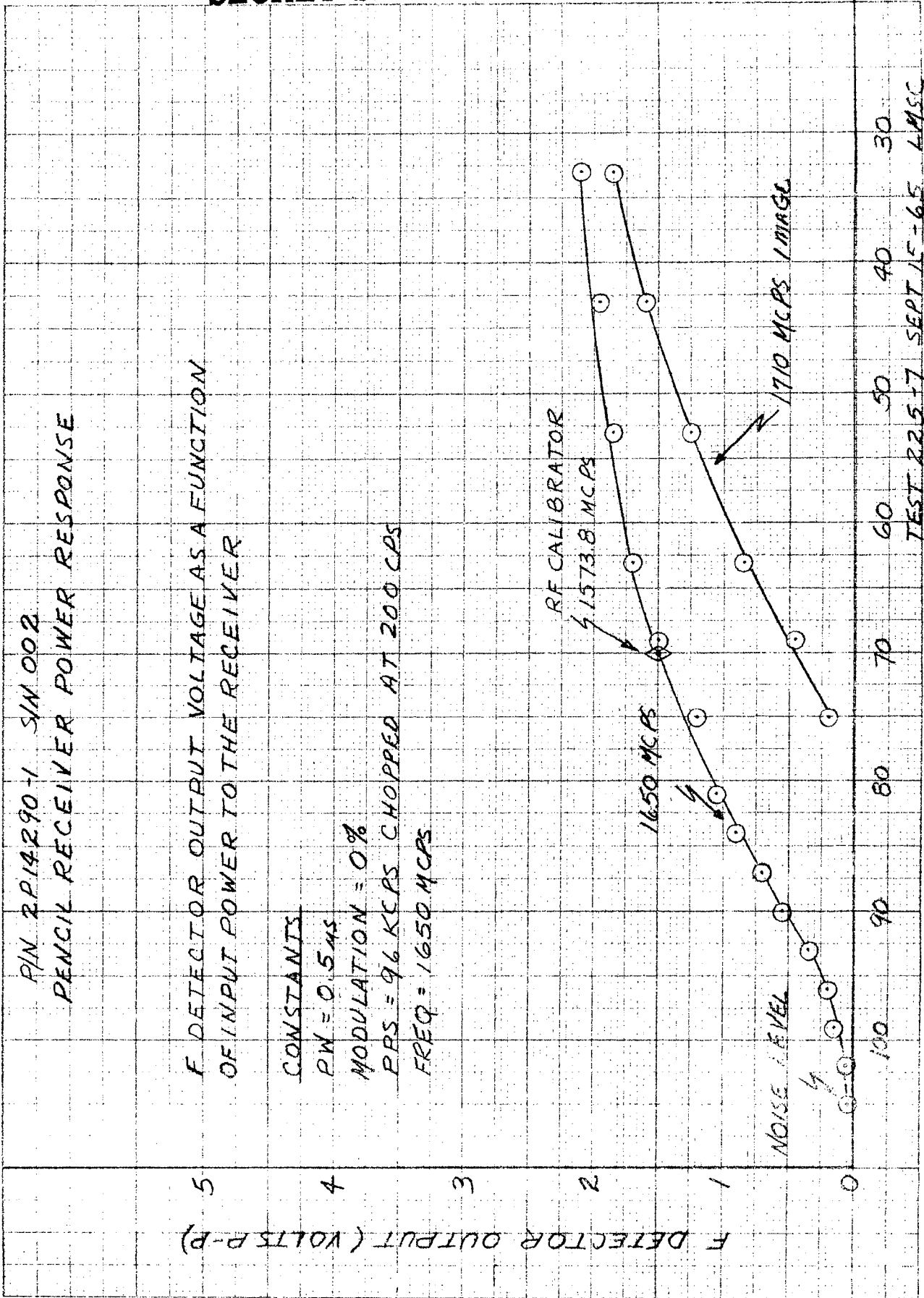

~~SECRET-SPECIAL HANDLING~~

~~SECRET~~ SPECIAL HANDLING AM 01 884

PN 2P14290-1 SINOOR
PENCIL RECEIVER POWER RESPONSE

F DETECTOR OUTPUT VOLTAGE AS A FUNCTION
OF INPUT POWER TO THE RECEIVER

CONSTANTS
PW = 0.5 μ S
MODULATION = 0%
PPS = 96 KC CHOPPED AT 800 CPS
FREQ = 1650 MCPS

CONSTANTS
PW = 0.5 μ S
MODULATION = 0%
PPS = 958 KCPS
FREQ = 1650 MCPS

RF CALIBRATOR 1573.8 MCPS

1710 MCPS IMAGE

F DETECTOR OUTPUT (VOLTS P-P)

INPUT POWER (-dbm)

TEST 22577 SEPT 15-65 LMSC

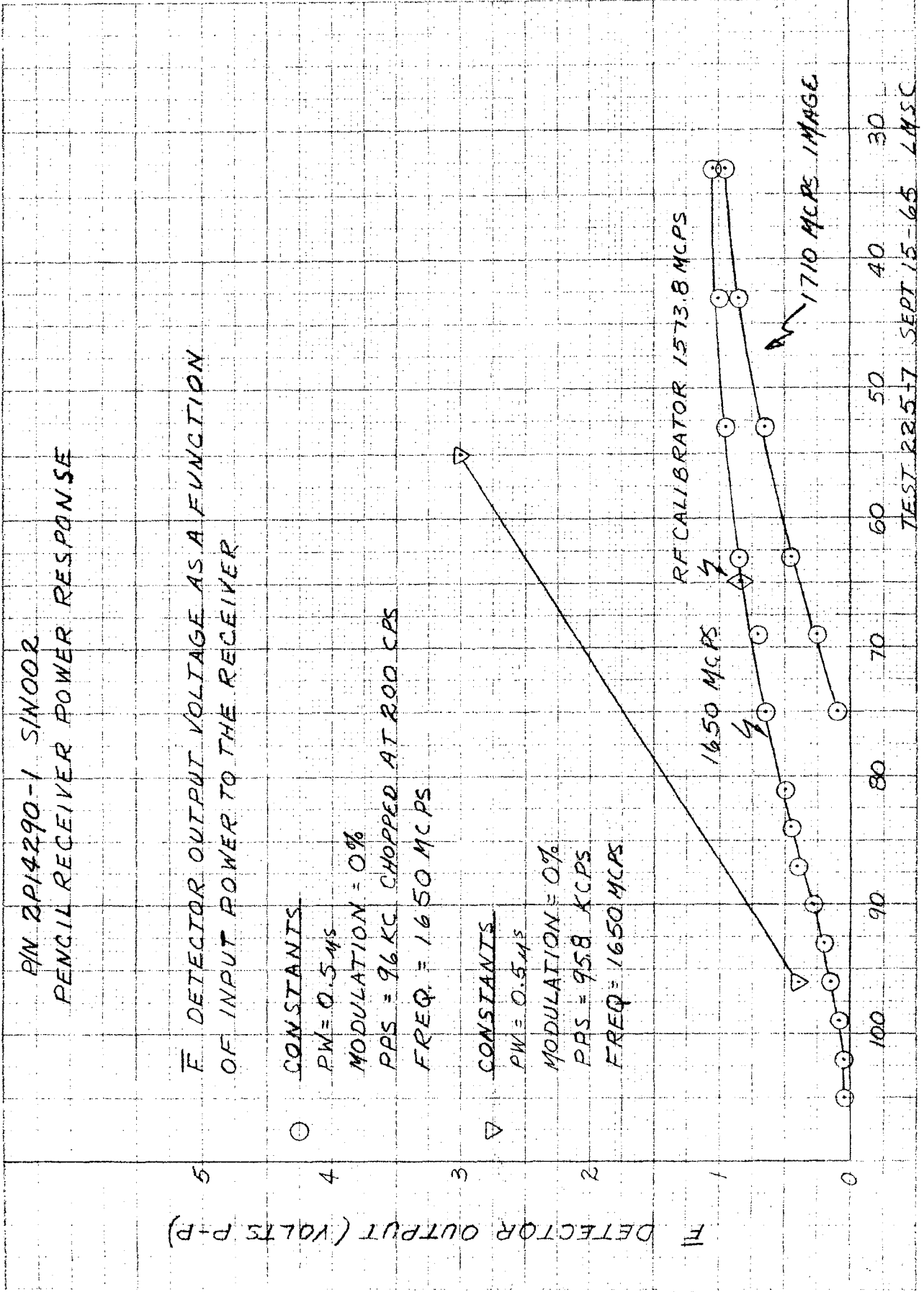

~~SECRET~~ SPECIAL HANDLING

~~SECRET - SPECIAL HANDLING~~

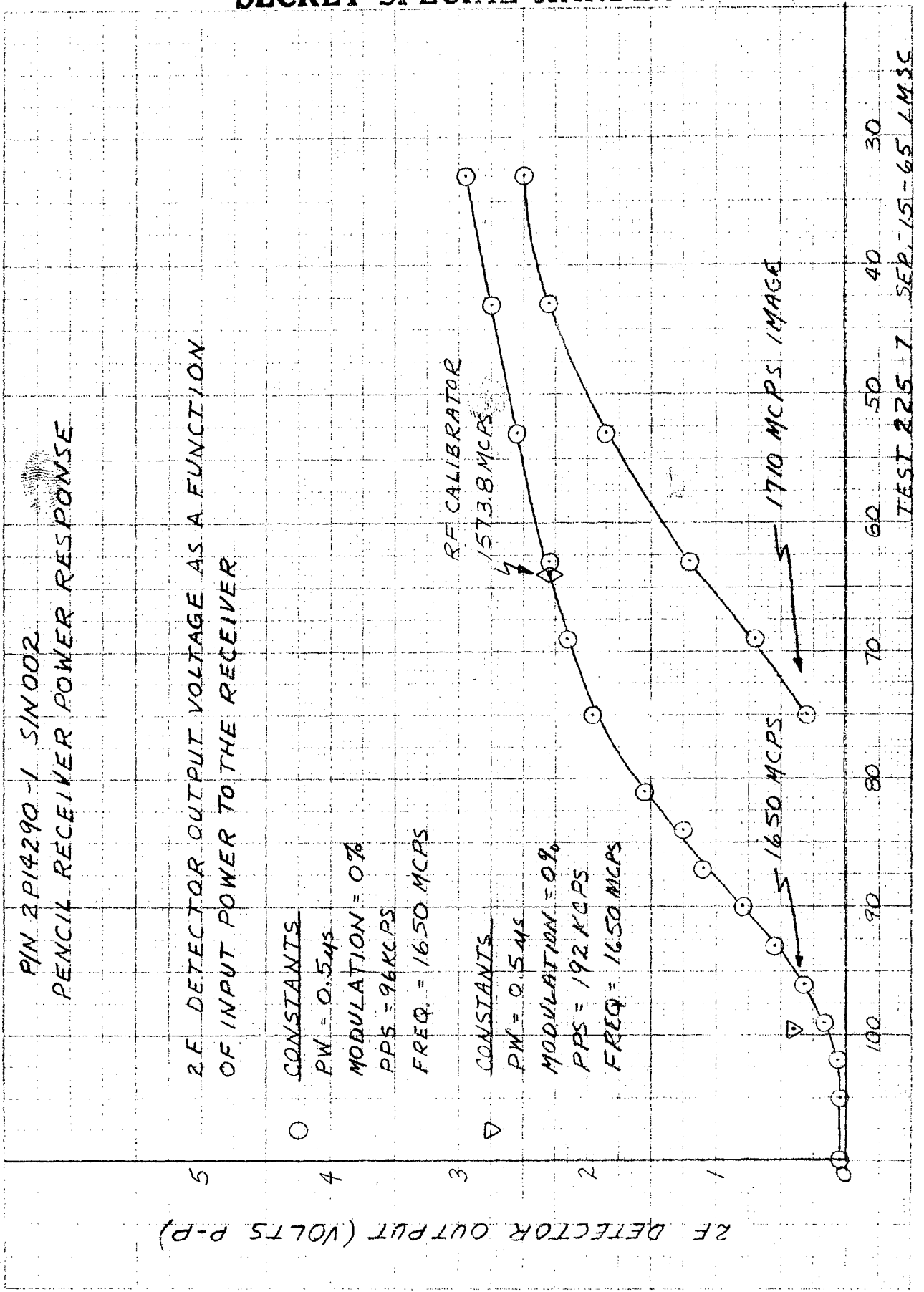

~~SECRET - SPECIAL HANDLING~~

INPUT POWER (-dbm)

~~SECRET SPECIAL HANDLING~~ AW 01884

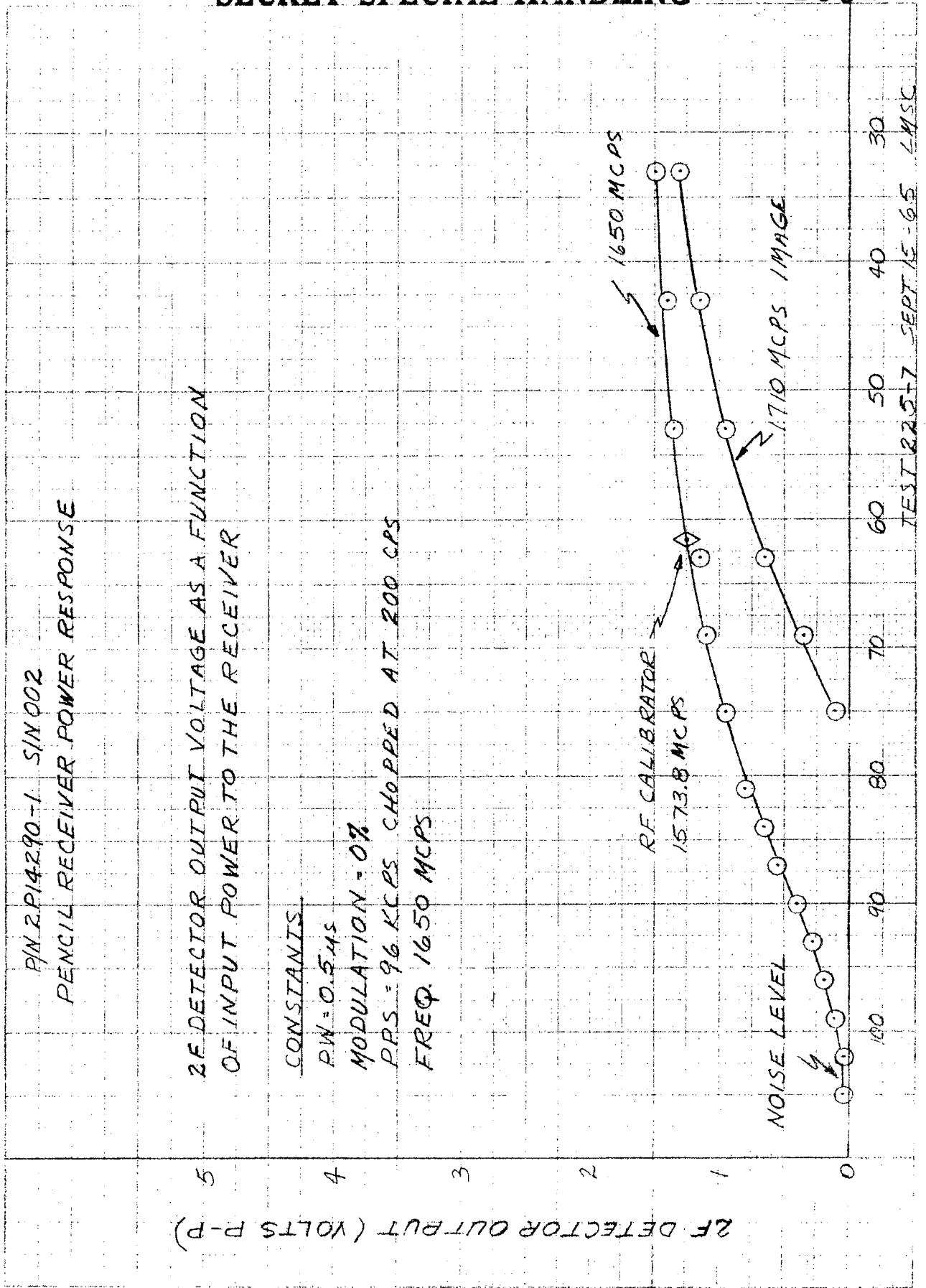

~~SECRET SPECIAL HANDLING~~

~~SECRET~~ ~~NO~~ HANDLING AN U1884

RIN 2P14290-1 S1002
PENCIL RECEIVER POWER RESPONSE

RF DETECTOR OUTPUT VOLTAGE AS A FUNCTION
OF INPUT POWER TO THE RECEIVER

RF DETECTOR OUTPUT (VOLTS P-P)

○ CONSTANTS

PW = 0.5 μs

MODULATION = 0%

PPS = 96 KCPS CHOPPED AT
200 CPS

FREQ = 16.50 MCPS

▽ CONSTANTS

PW = 0.5 μs

MODULATION = 0%

PPS = 191.8 KCPS

FREQ = 16.50 MCPS

RF CALIBRATOR 1573.8 MCPS

16.50 MCPS

1710 MCPS IMAGE

TEST 225-7 SEPT 15-65 LMSC

INPUT POWER (-dbm)

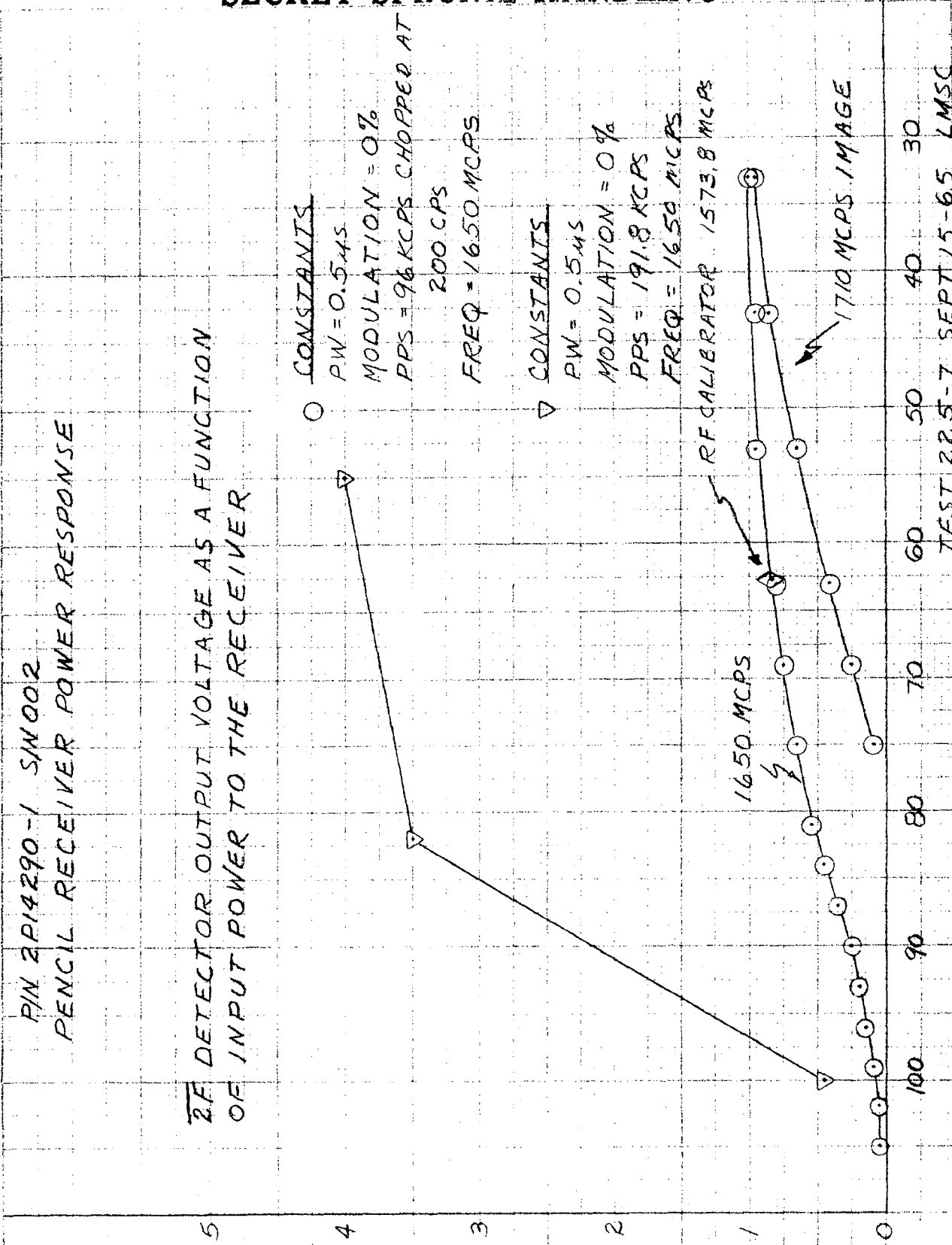

~~SECRET~~

~~SECRET~~ AW 01884

EUGENE DIETZGEN CO.
MADE IN U. S. A.

NO. 340-20 DIETZGEN GRAPH PAPER
20 X 20 PER INCH

P/N 2P14290-1

PENCIL BEAM
TEMPERATURE 800°
S/N 002

NOTE: ADD +3 TO ALL dbm VALUES TO
OBTAIN TRUE RECEIVER INPUT POWER.

FOR EXAMPLE: -63 dbm + 3 db = -60 dbm

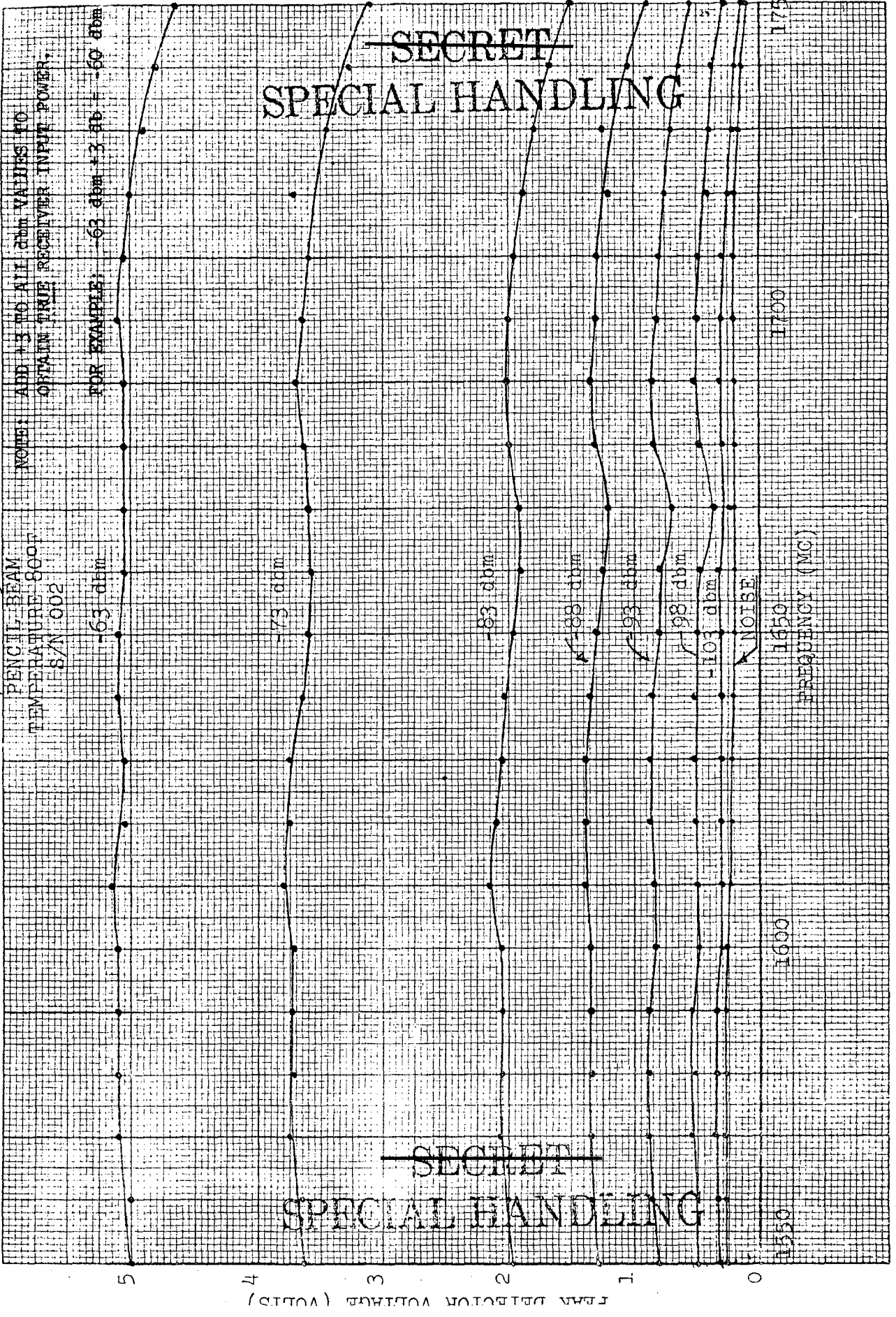

FIGURE 20

EUGENE DIETZGEN CO.
MADE IN U. S. A.

NO. 34C-20 DIETZGEN GRAPH PAPER
20 X 20 PER INCH

P/N 2P14290-1

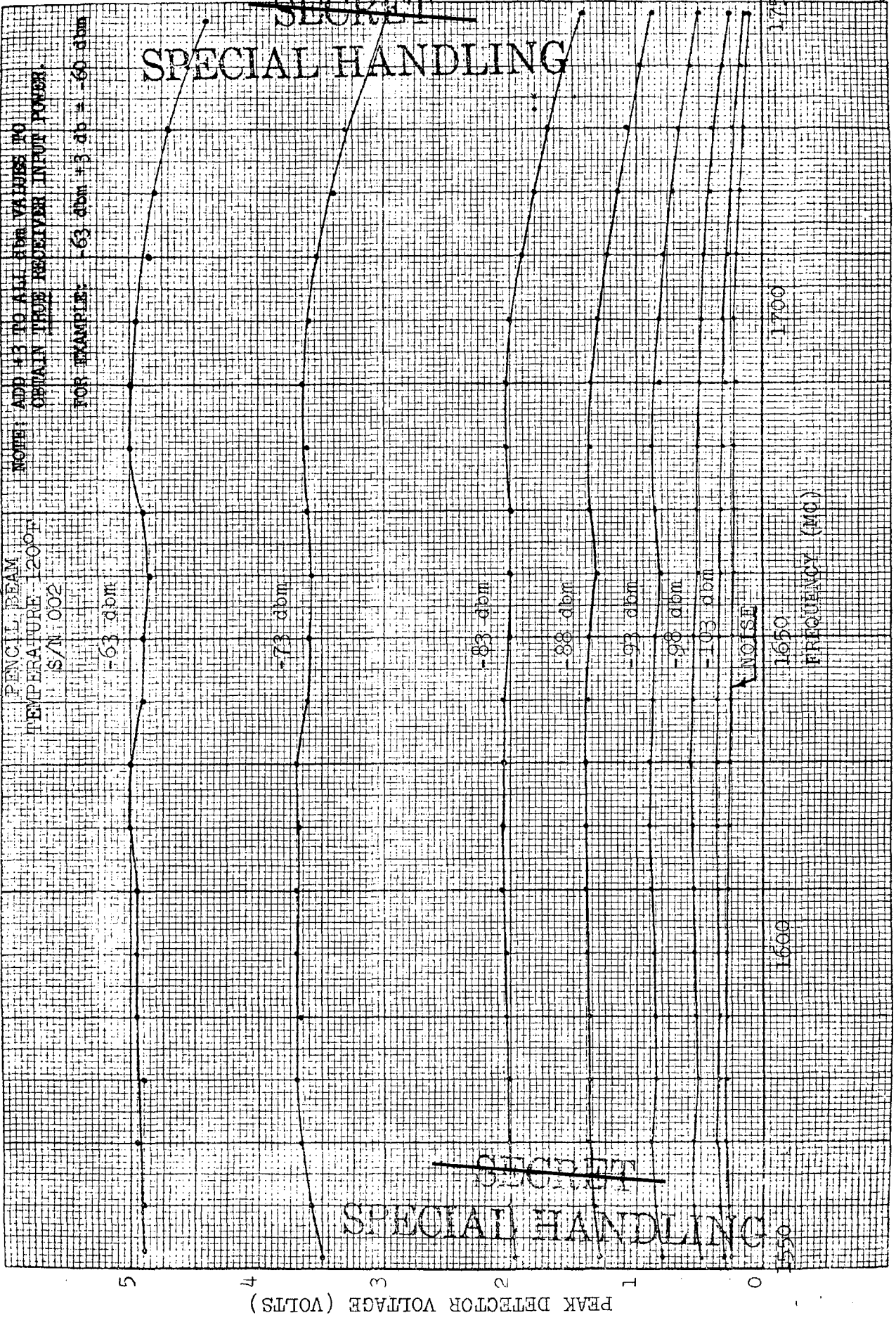

FIGURE 21

~~SECRET~~
AWUL 184

EUGENE DIETZGEN CO.
MADE IN U. S. A.

NO. 34D-20 DIETZGEN GRAPH PAPER
20 X 20 PER INCH

P/N 2P14290-1

PENCIL BEAM
TEMPERATURE 400F
S/N 002

NOTE: ADD +1 TO ALL dbm VALUES TO
OBTAIN TRUE RECEIVER INPUT POWER.
FOR EXAMPLE: -63 dbm + 3 db = -60 dbm

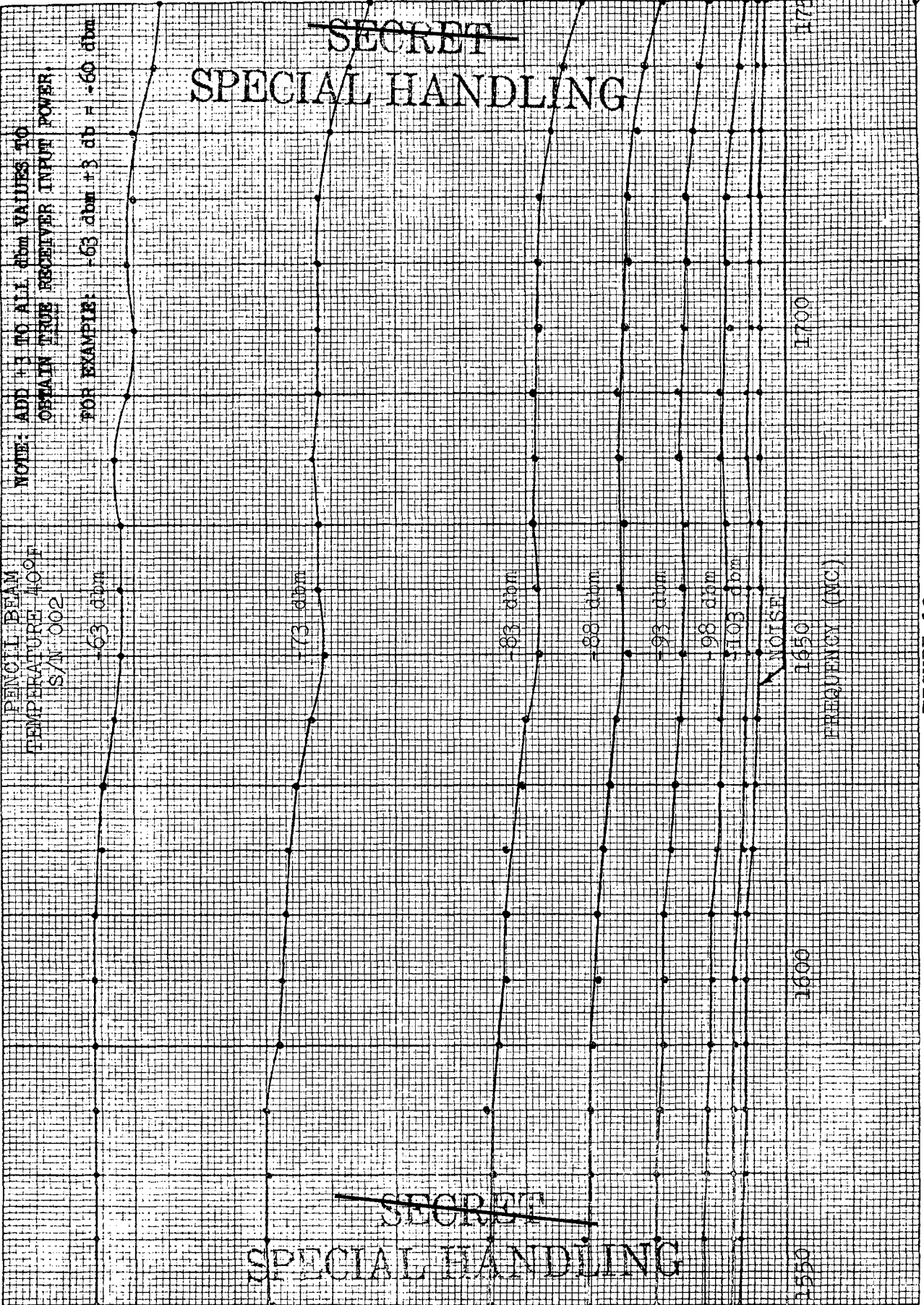

~~SECRET~~
SPECIAL HANDLING

~~SECRET~~
SPECIAL HANDLING

FIGURE 19

~~SECRET~~

EUGENE DIETZGEN CO.
MADE IN U. S. A.

NO. 340-20 DIETZGEN GRAPH PAPER
20 X 20 PER INCH

P/N 2P14290

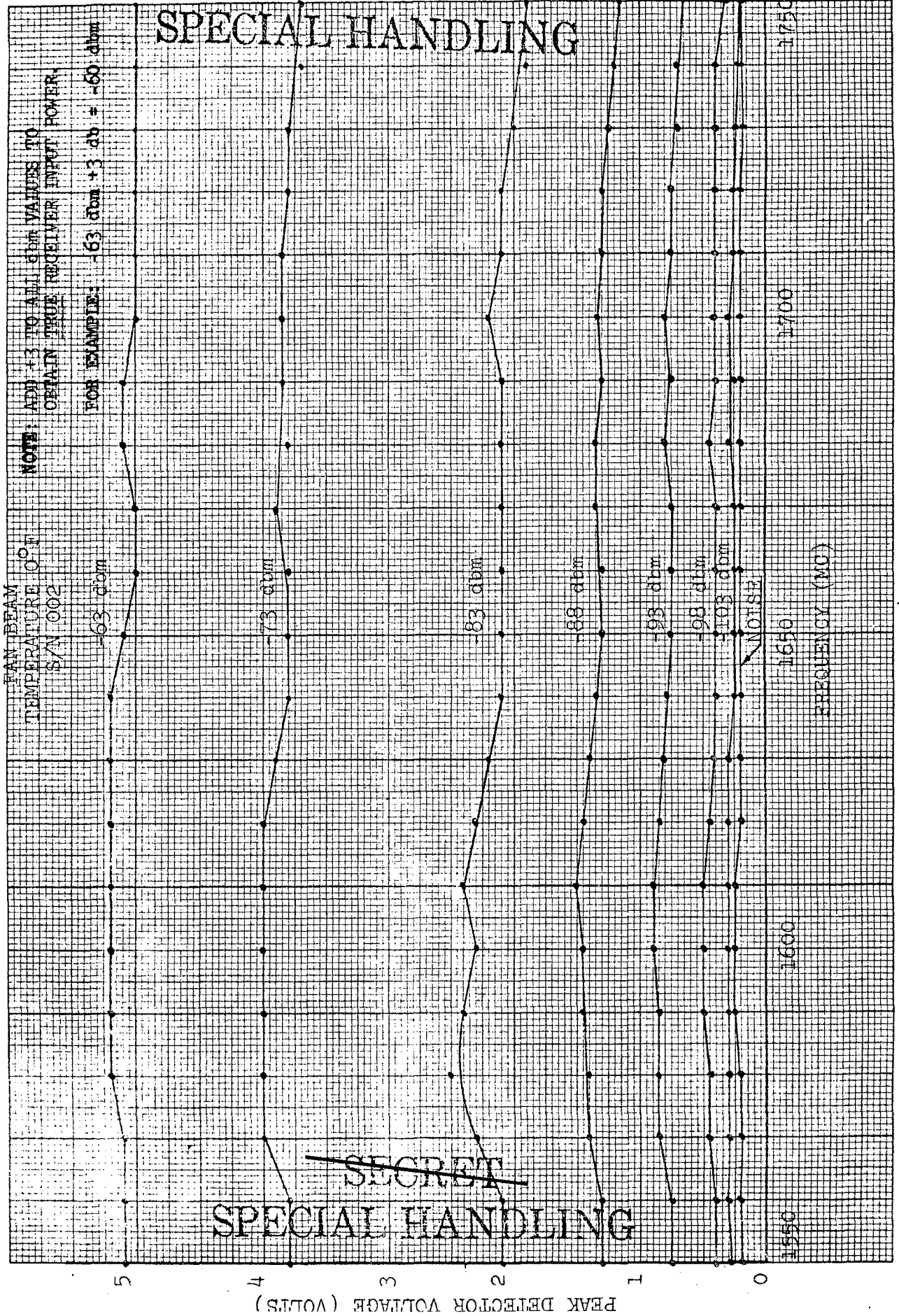

~~SECRET~~
SPECIAL HANDLING

FIGURE 14

~~SECRET~~ AW 01884

EUGENE DIETZGEN CO.
MADE IN U. S. A.

NO. 34D-20 DIETZGEN GRAPH PAPER
20 X 20 PER INCH

P/N 2P14290-1

FAN BEAM
TEMPERATURE 40°F
S/N 1002

NOTE: ADD +3 TO ALL dbm VALUES TO
OBTAIN TRUE RECEIVER INPUT POWER.

FOR EXAMPLE: -63 dbm +3 db = -60 dbm

~~SECRET~~
SPECIAL HANDLING

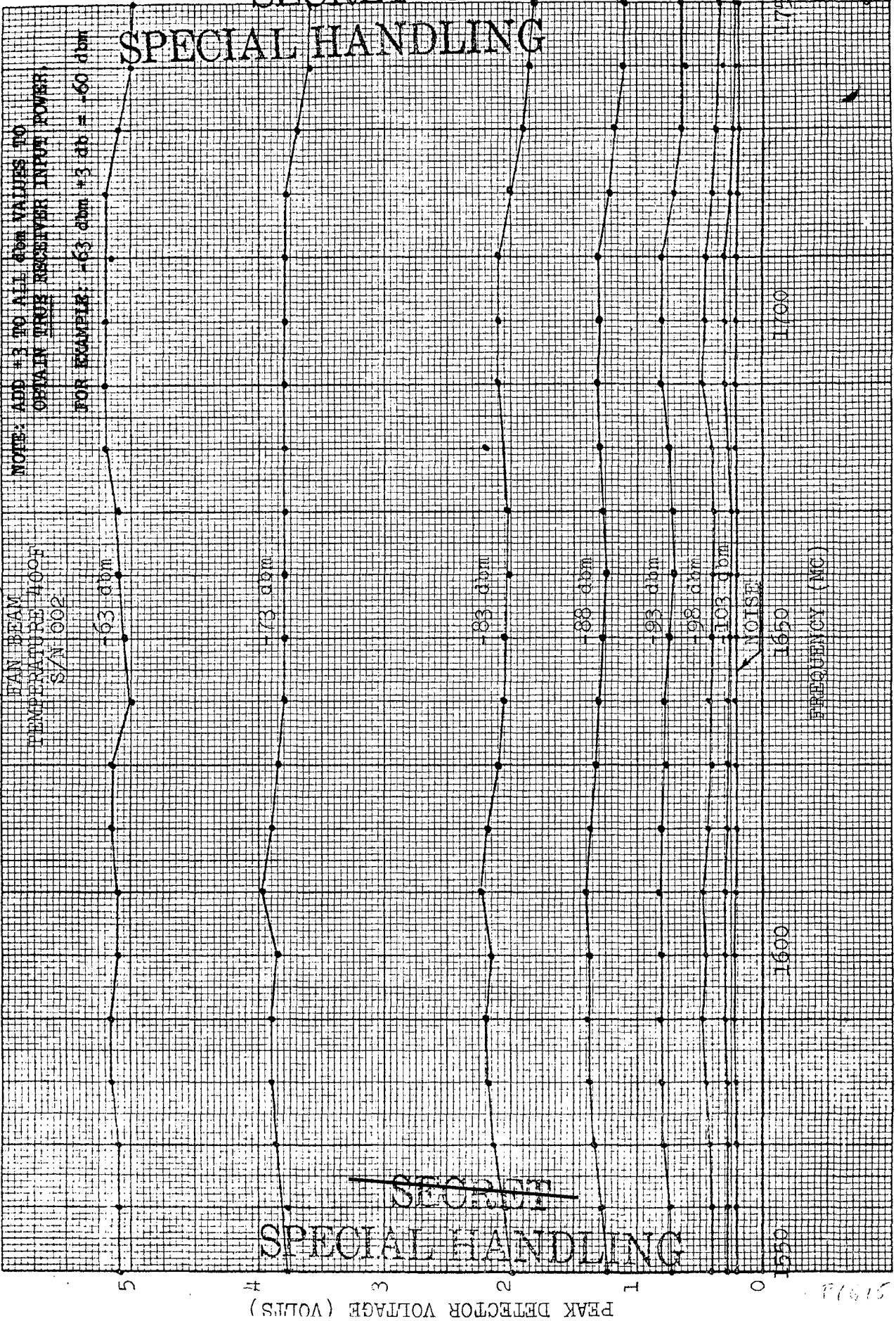

~~SECRET~~
SPECIAL HANDLING

FIGURE 15

EUGENE DIETZEN CO.
MADE IN U. S. A.

NO. 340-20 DIETZEN GRAPH PAPER
20 X 20 PER INCH

P/N 2P14290-1

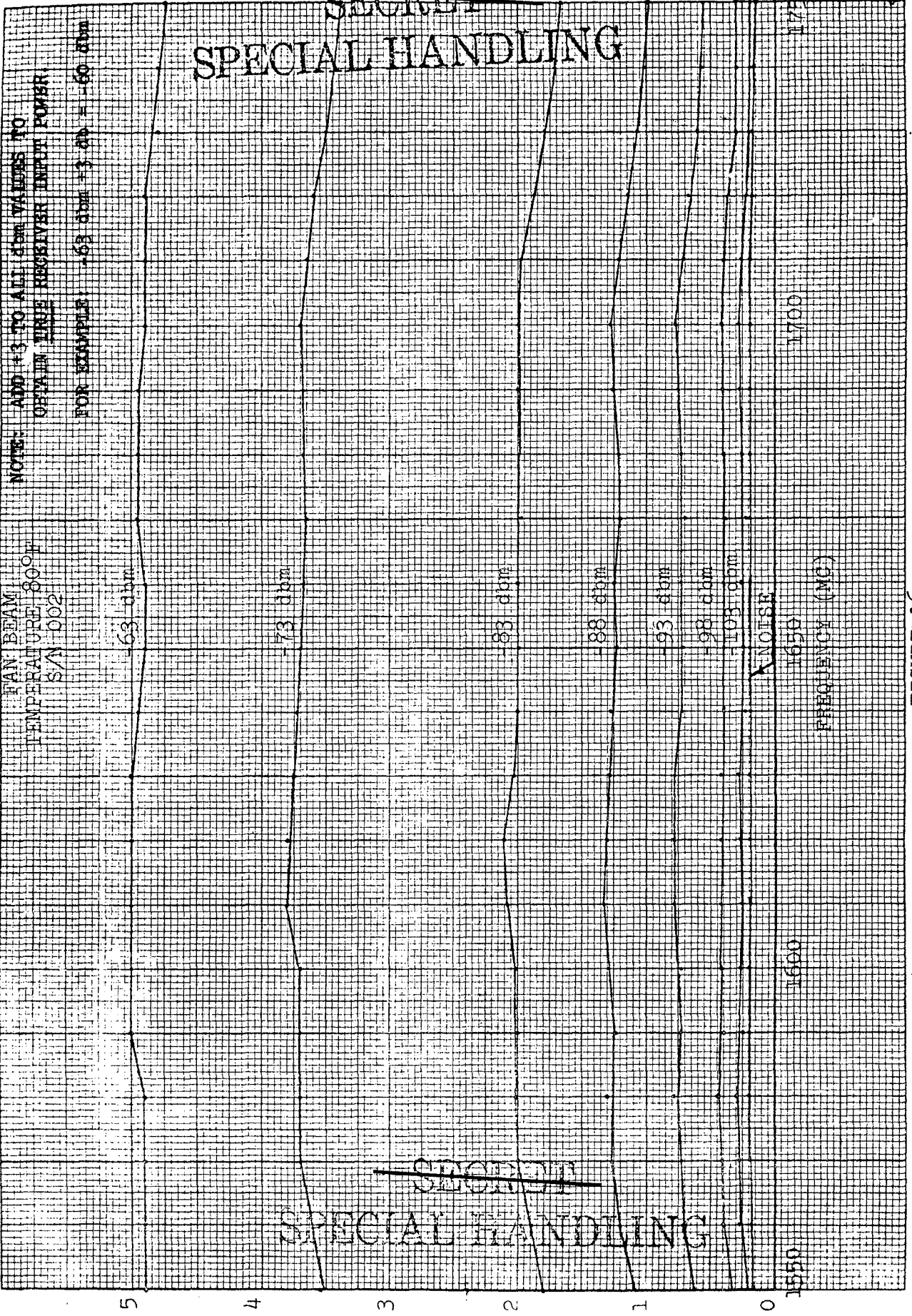

FIGURE 16

~~SECRET~~

SPECIAL HANDLING

EUGENE DIETZGEN CO.
MADE IN U. S. A.

NO. 340-20 DIETZGEN GRAPH PAPER
20 X 20 PER INCH

P/N 2P14290-1

TRAN BEAM
TEMPERATURE 120°F
S/N 002

NOTE: ADD +3 TO ALL dBm VALUES TO
OBTAIN TRUE RECEIVER INPUT POWER.

FOR EXAMPLE: -63 dBm + 3 db = -60 dBm

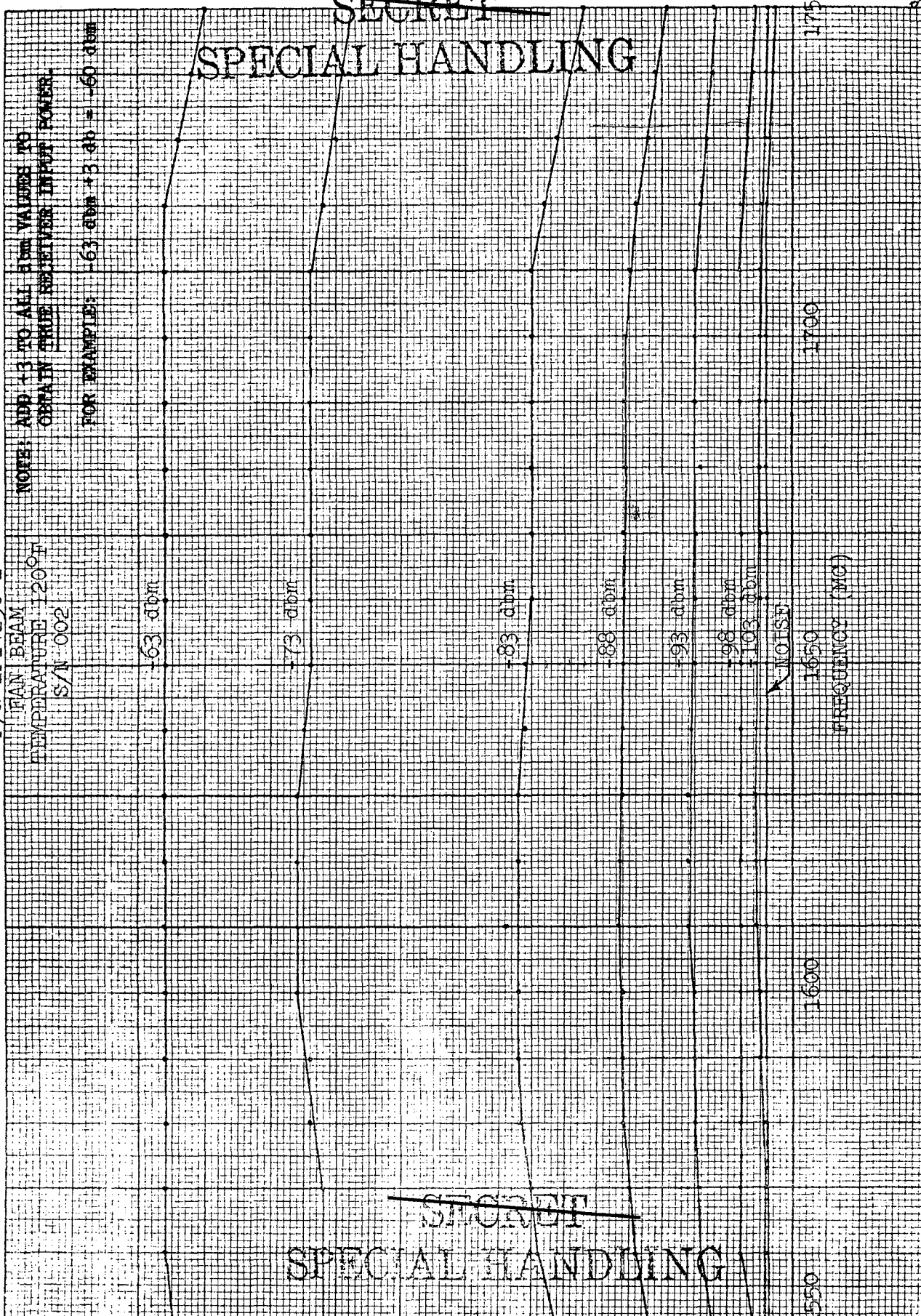

NOISE

BEAM DETECTOR VOLTAGE (VOLTS)

550

1600

1650

1700

1750

FREQUENCY (MC)

FIGURE 17

~~SECRET~~
SPECIAL HANDLING

AW 01884

53300-3247
Page 2648

~~SECRET~~

SPECIAL HANDLING

EUGENE DIETZGEN CO.
MADE IN U. S. A.

NO. 340-20 DIETZGEN GRAPH PAPER
20 X 20 PER INCH

P/N 2PI4290-1

PENCIL BEAM

TEMPERATURE 100°F

S/N 002

NOTE: ADD +3 TO ALL dBm VALUES TO
OBTAIN FREE RECEIVER INPUT POWER.

FOR EXAMPLE: -63 dBm + 3 dB = -60 dBm

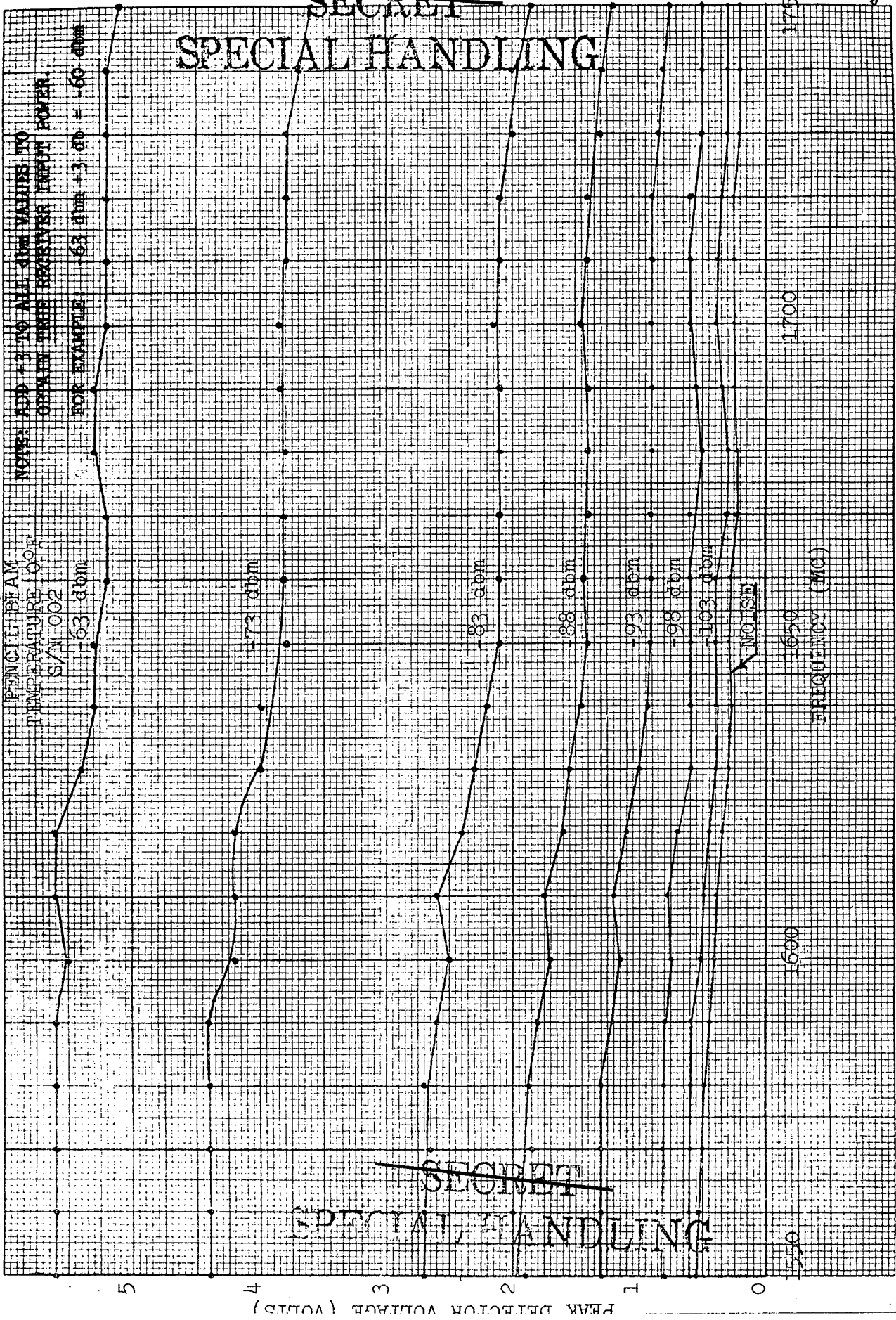

~~SECRET~~
SPECIAL HANDLING

FIGURE 18

~~SECRET-SPECIAL HANDLING~~

AW 01884

FAN BEAM CHANNEL
POWER RESPONSE

REFERENCE PARAGRAPH IV

FAN CHANNEL

* CONSTANTS

PW = 0.5 MS

MODULATION = 0%

PPS = 96 K CPS

FREQ. = 1650 MCPS

RECEIVER INPUT POWER (-dbm)	DETECTOR OUTPUTS			COMMENTS
	PEAK (VOLTS)	F (VP-P)	2F (VP-P)	
NO INPUT	.2	.06	.05	NOISE LEVELS
102	.2	.14	.11	
99	.3	.25	.21	4 LEVEL SUMMER THRESHOLD
96	.39	.45	.38	
63	4.7	3.2	2.5	
33	5.75	4.0	3.1	
RFC NON-VALID (200 n CHOP)	1.45	1.65	1.25	
RFC VALID	1.5	3.15	2.25	

* EXTERNAL INPUT SIGNALS ONLY

~~SECRET-SPECIAL HANDLING~~

~~SECRET-SPECIAL HANDLING~~

AW01884

2814290-1 SN002

PENCIL RECEIVER RESPONSE TO
PULSE WIDTH VARIATIONS

1.0

PEAK DETECTOR VOLTS DC
'F' DETECTOR VOLTS P-P

CONSTANTS

INPUT PWR = -26 dbm
FREQUENCY = 1650 Mcps
0% CHAN. MODULATION

F DETECTOR OUTPUT
V P-P VS PULSE WIDTH
@ 96 KPPS

@ 24 KPPS

PEAK DETECTOR
OUTPUT VOLTS DC
VS PULSE WIDTH
@ 96 KPPS

@ 24 KPPS

0.25

0.5

0.75

1.0

PULSE WIDTH IN MICROSECONDS

TEST 285-Y, 13 SEPT 65, 4M35

~~SECRET-SPECIAL HANDLING~~

~~SECRET-SPECIAL HANDLING~~

AW 01884

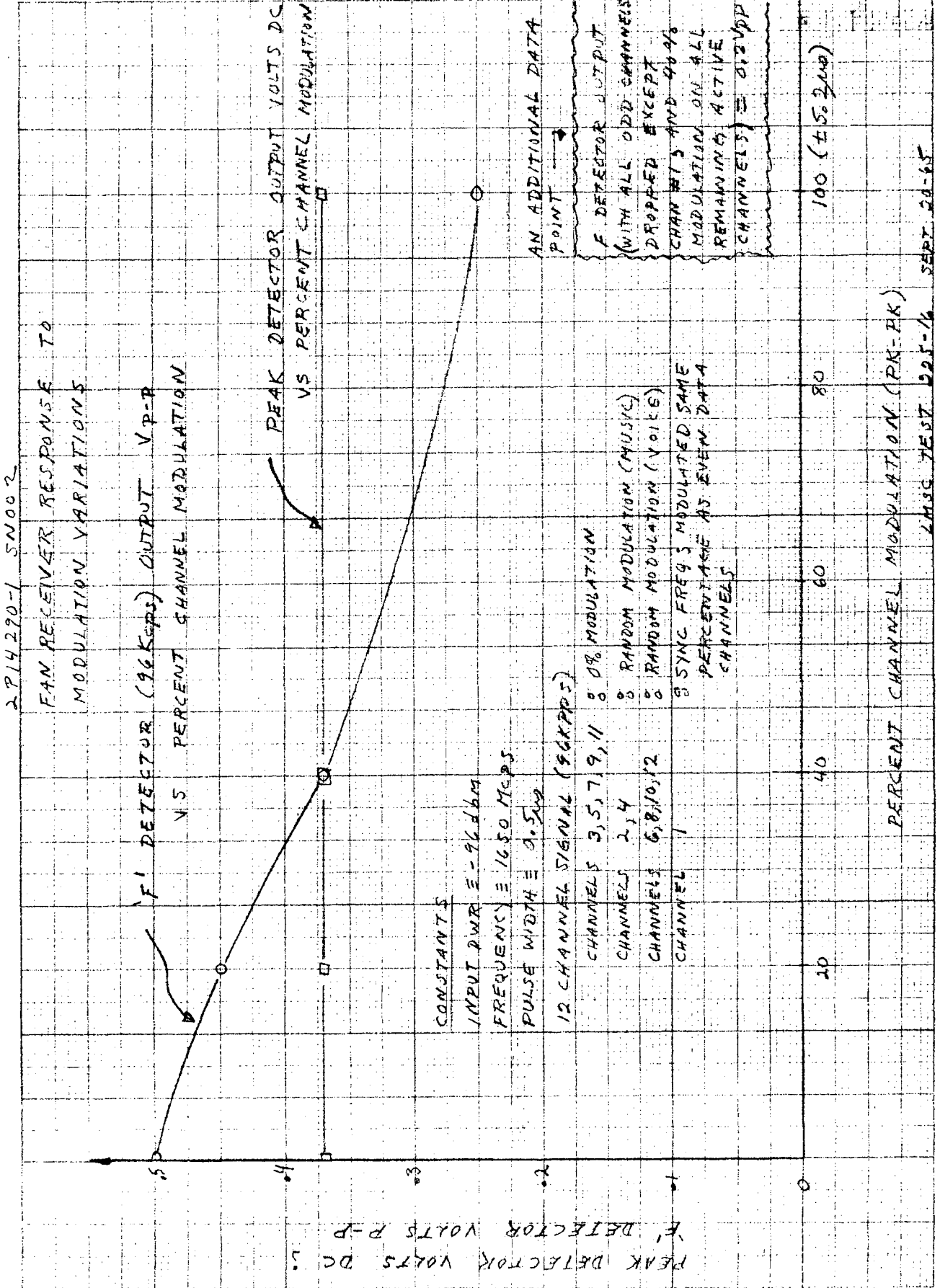

~~SECRET-SPECIAL HANDLING~~

~~SECRET~~ ~~CONTROL HANDLING~~

1384

AW 01884

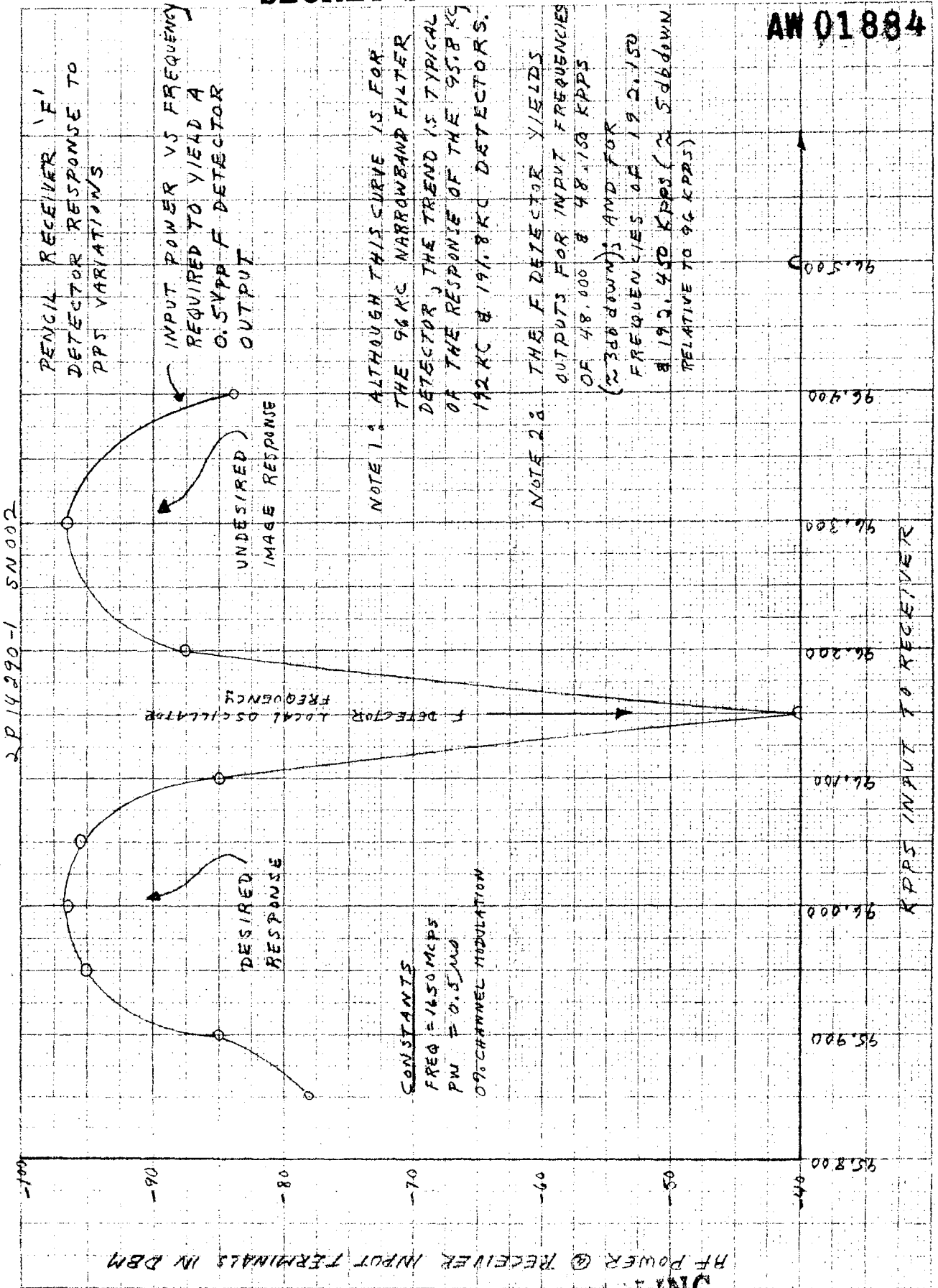

FRESECK POST COMPANY
ARTISTON CROSS STREET
NEW YORK PER INCH

~~SECRET~~

~~CONTROL HANDLING~~

~~SECRET-SPECIAL HANDLING~~ AW 01884

2.P14270-1 5M002

FAN, PENCIL RECEIVER PASSBAND RESPONSE

INPUT POWER REQUIRED AS A FUNCTION
OF FREQUENCY TO RESULT IN A
VIDEO PEAK DETECTOR OUTPUT VOLTAGE
(SIGNAL + NOISE) OF 0.4 VDC

CONSTANTS

12 CHANNEL SIGNAL (96 KC)

PW = 0.5 μS

0% CHAN. MODULATION

PEAK POWER @ REVR INPUT TERMINALS IN dBm

VIDEO PEAK DETECTOR NOISE VOLTS
VS FREQUENCY

SIGNAL FREQUENCY IN MCPS

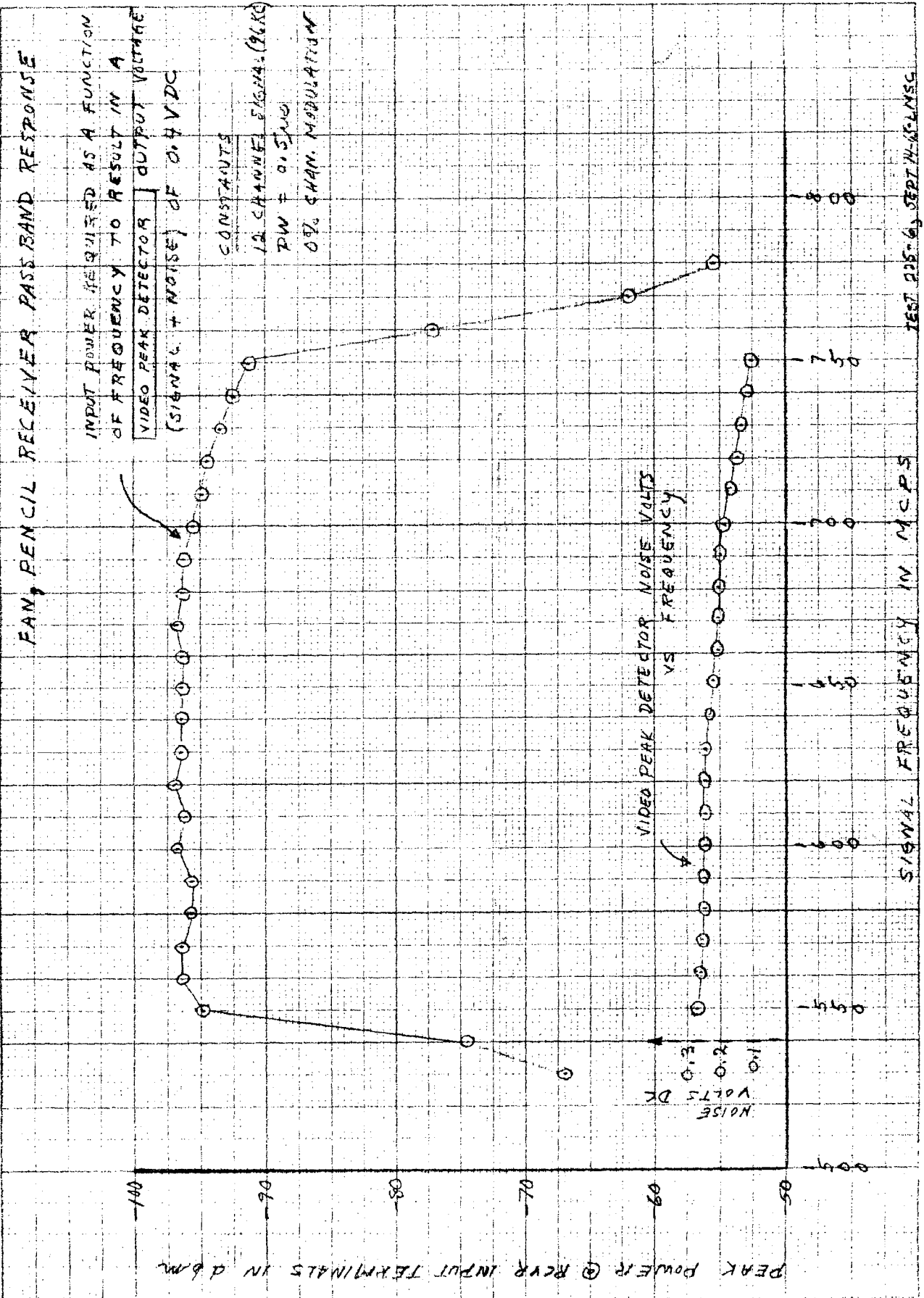

TEST 225-6, SEPT 24-25, 1953

~~SECRET-SPECIAL HANDLING~~

~~SECRET-SPECIAL HANDLING~~ AW 01884

2 P14290-1 SN002

FAN, PENCIL RECEIVER PASSBAND RESPONSE

INPUT POWER REQUIRED AS A FUNCTION OF FREQUENCY TO RESULT IN THE 'F' DETECTOR OUTPUT VOLTAGES SHOWN

OUTPUT VOLTAGE (STN)

96 KC DETECTOR 0.45

192 KC DETECTOR 0.75

CONSTANTS
12 CHANNEL SIGNAL
P.W. = 0.5 SEC
0% CHAM. MODULATION

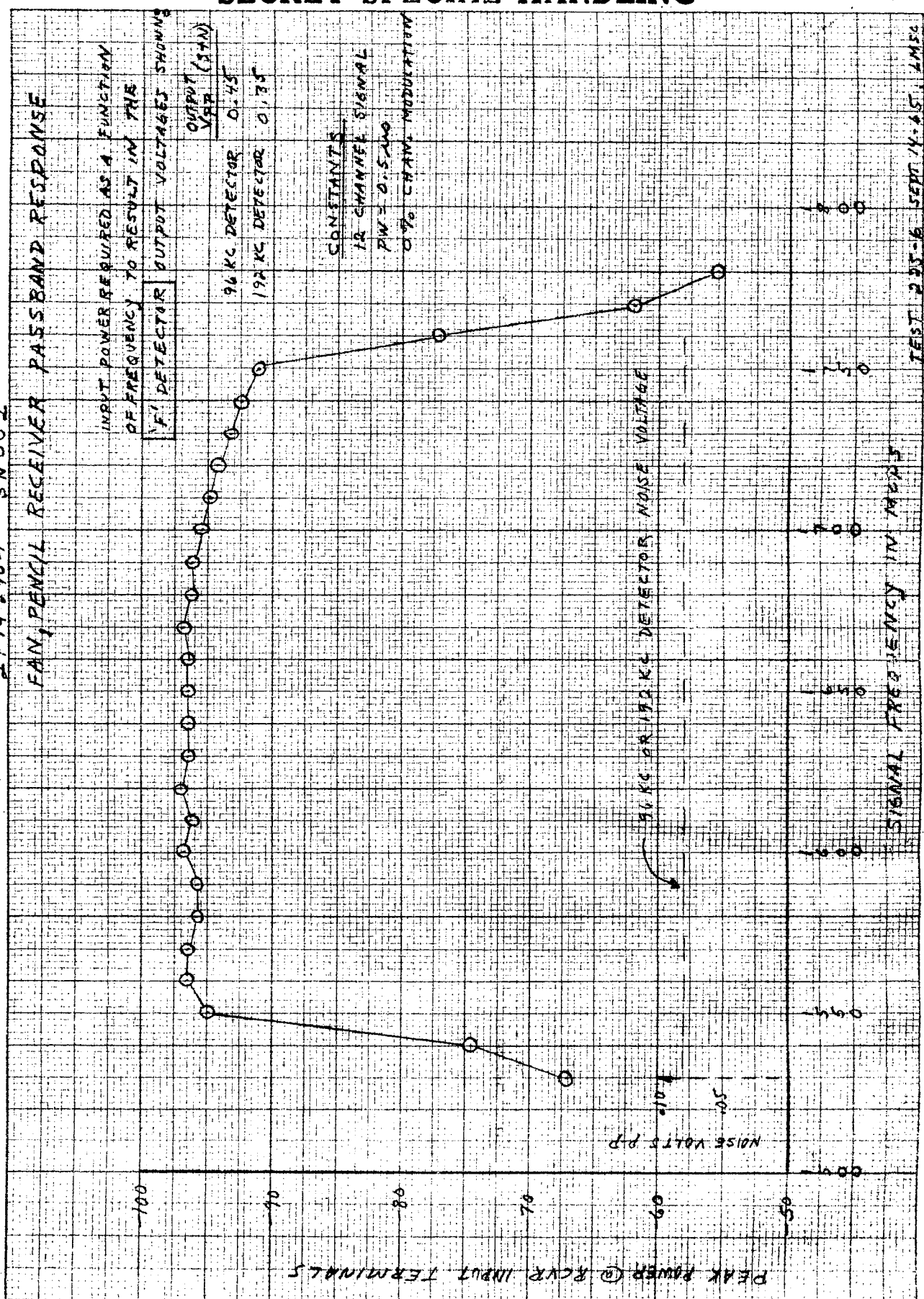

TEST 205-6 SEPT 14-45 LAMEC

~~SECRET-SPECIAL HANDLING~~

~~SECRET~~

AW01884

~~SPECIAL HANDLING~~

P/N 2P11290-1

S/N 002 & 001

TEMPERATURE MONITOR VOLTAGE VS. TEMPERATURE (BASEPLATE)

(04-10-53)

TEMPERATURE MONITOR VOLTAGE (VOLTS)

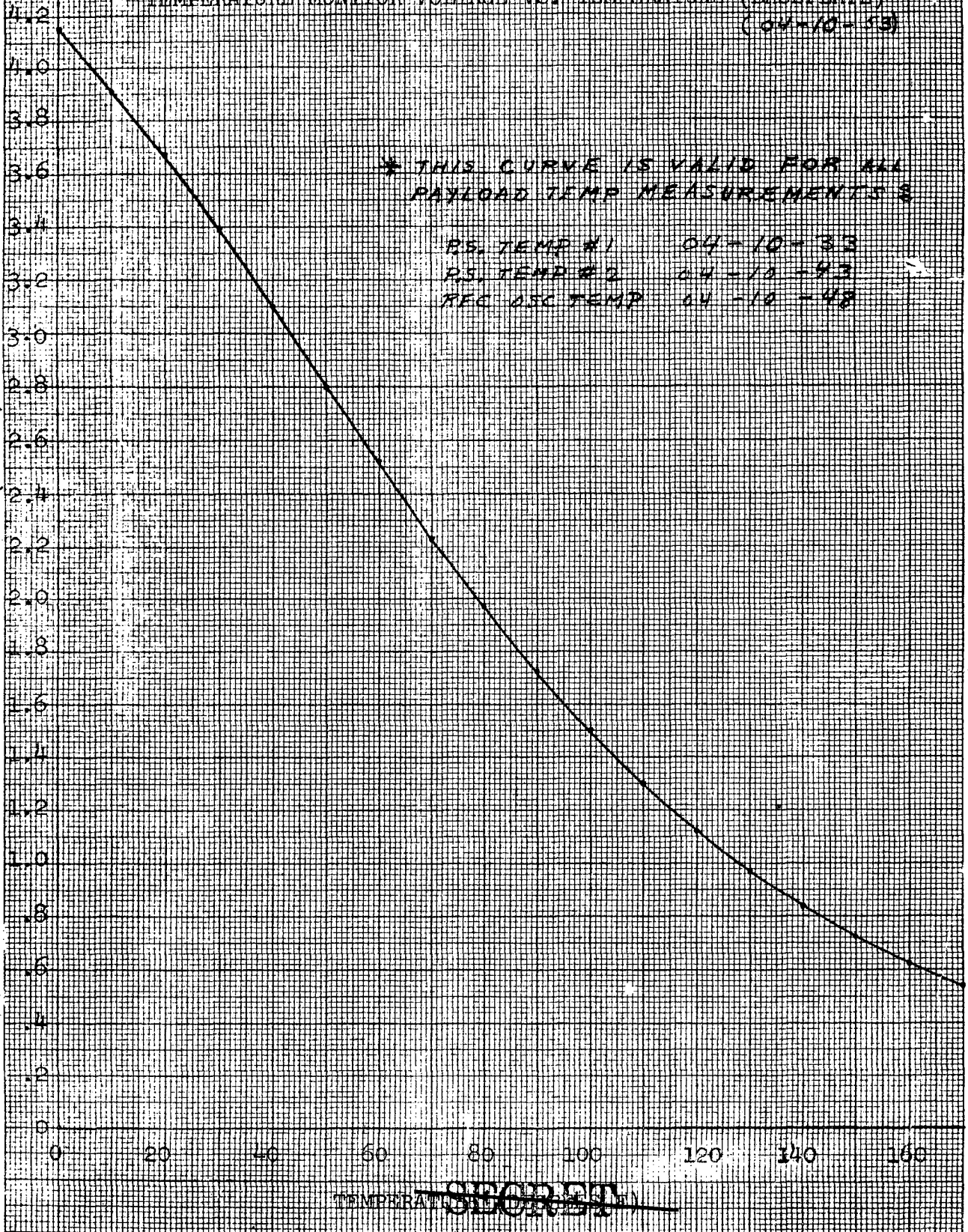

* THIS CURVE IS VALID FOR ALL PAYLOAD TEMP MEASUREMENTS *

RS. TEMP #1 04-10-33
 RS. TEMP #2 04-10-43
 REC OSC TEMP 04-10-48

EUGENE DIETZGEN CO.
MADE IN U. S. A.

NO. 340-MP DIETZGEN GRAPH PAPER
MILLIMETER

~~SECRET~~

FIGURE 1
~~SPECIAL HANDLING~~