

~~SECRET//BYE//TK//X1~~

GAMBIT Film Bucket (M4352) Reentry Plan

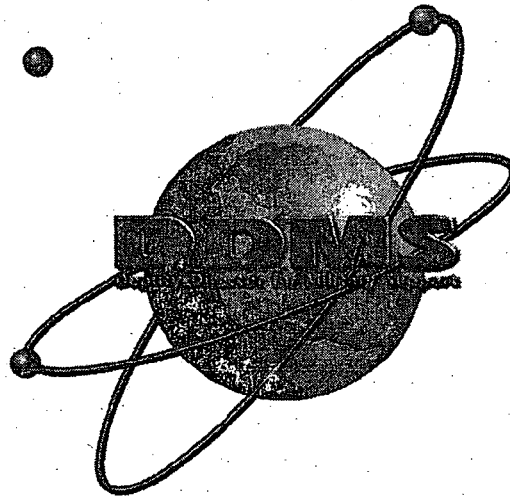
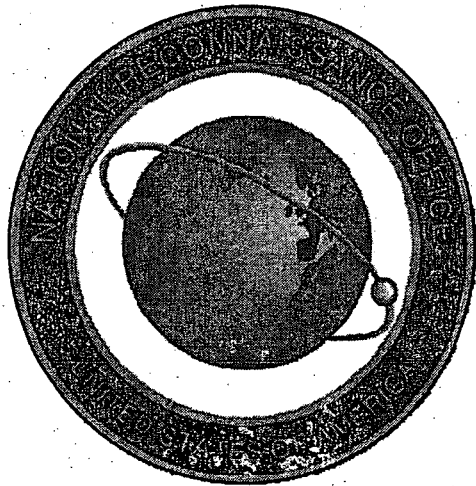

September 2002

The Overall Classification of this Briefing is: ~~S//BYE//TK~~

Warning: This document may not be used as a source of derivative classification.

(b)(3)

Classified By:
CI Reason:
Decl On:
Derived from:

1.5 C
X1
NCG 5.1 01 May 00

~~SECRET//BYE//TK//X1~~

Handle Via
~~BYEMAN and TALENT KEYHOLE~~
Channels Jointly

~~SECRET//BYE//TK//X1~~Slide 2
20-Sep-02

Background on M4352 (GAMBIT) (1 of 2)

- **NRO film-return satellite reconnaissance system**

- Operational from the early 1960s through early 1980s (KH-7 and KH-8)
- Designed to collect high-resolution surveillance imagery
 - Best-ever resolution
 - KH-7: 1.6 feet
 - KH-8:
- Mission duration
 - KH-7: 4 to 6 days
 - KH-8: 45 to 126 days
- Film return process
 - “Buckets” separated from the satellite
 - Thrusters fired to cause bucket to reenter
 - Parachute deployed at 3G deceleration
 - Specially equipped C-130 retrieved the bucket before impact

- **M4352 (KH-8)**

- Launched 21 Jan 1982
- New-design separation squib malfunctioned on first film bucket, stranding it on orbit
 - 20-year orbit decay predicted
 - Second film bucket successfully deorbited and recovered

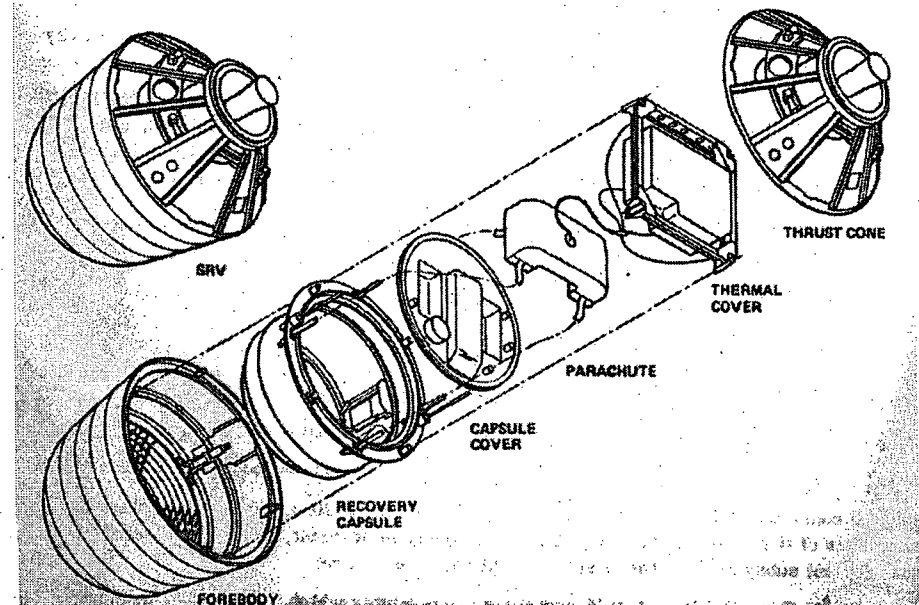
(b)(1)
(b)(3)~~SECRET//BYE//TK//X1~~

~~SECRET//BYE//TK//X1~~

Background on M4352 (GAMBIT) (2 of 2)

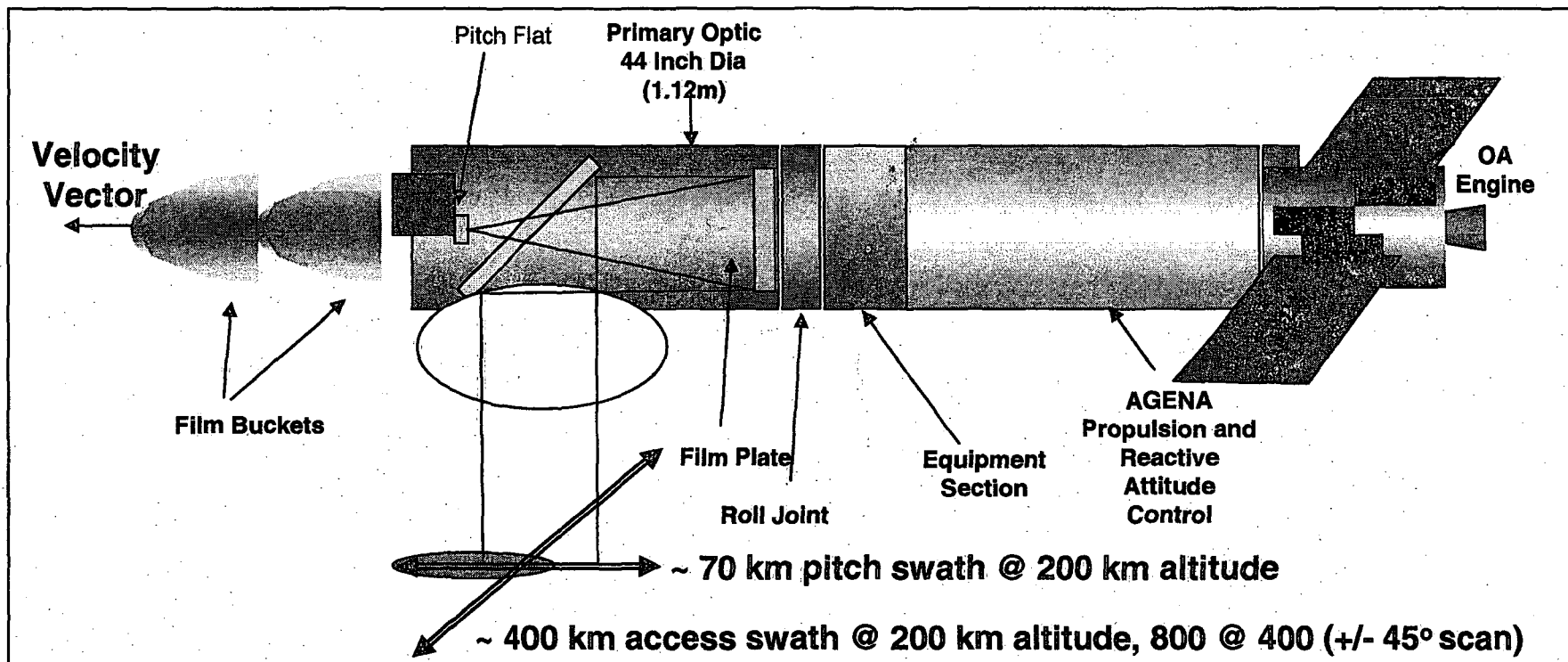

~~SECRET//BYE//TK//X1~~

~~SECRET//BYE//TK//X1~~

Slide 4
20-Sep-02

GAMBIT Bucket Reentry Analysis (As of 19 Sep 2002)

- **Uncontrolled reentry is predicted for 25 – 28 Sep 02**
 - Current Cheyenne Mountain prediction is 26 Sep 02, with 99% probability of reentry within stated window
- **Because the reentry will be uncontrolled, accurate prediction of reentry location not practical until 4 to 6 hours prior to reentry**
 - No actions can be taken to change reentry location or time
- **Under 100 pounds of material, approx 20 inches in diameter, expected to survive reentry**
 - Surviving debris expected to have the equivalent mass of a 19-inch TV
 - The film and its takeup expected to be the only hazardous object to survive
 - Outer layers and edges of film may be charred; inner layers and takeup motor could survive in a recognizable form
 - Stub antennas, door covering the film port, 6 pounds of steel wire in the main parachute could survive.
- **IF the GAMBIT film bucket falls on land or into shallow or foreign waters, appropriate assistance will be sought in accordance with existing processes/procedures**
 - Emergency search and recovery assistance through Joint Staff/DDGO
 - Diplomatic notifications through State Department

~~SECRET//BYE//TK//X1~~

~~SECRET//BYE//TK//X1~~Slide 5
20-Sep-02

Sensitive Components for Recovery

- **IMINT determined sensitive components limited to exposed film**
 - CIA and NIMA Counterintelligence evaluated concerns with film recovered by non-US
 - Concerns with intel targeting and capability that could be extracted
- **Aerospace Corp (El Segundo) survivability analysis indicates potential for inner layers of exposed film to survive to the ground**
 - Analysis based on [redacted] and previous program knowledge (b)(1)
(b)(3)
 - Survivability relationships derived from the VAST (Vehicle Atmospheric Survivability Test) experiments of the early 1970s and consistent with a number of recent reentries:
[redacted] MIR and CGRO
 - Planning for worst case scenario. Coordination is in process to implement emergency search and recovery procedures
- **[redacted] infrared sensor observations at low altitudes during reentry would indicate surviving debris and provide likely impact location** (b)(1)
(b)(3)
 - Sensors will not be able to identify which components survive reentry
 - Decision to search and recover would be made based on sensor data, estimates of amount and location of surviving debris, and survivability analysis results

~~SECRET//BYE//TK//X1~~

~~SECRET//BYE//TK//X1~~

Slide 6
20-Sep-02

~~(C)~~ Operation



-- What is it?

(b)(1)
(b)(3)

- **Optional DNRO Tool to Task DoD to Perform:**
 - Emergency Recovery of Classified Satellite Debris
 - Launch Failure Beyond Immediate Pad Area
 - Anomalous Deorbit or Uncontrolled Reentry

- **Appropriate when:**
 - Potential for Compromise to National Security Exists
 - When Satellite Debris Lands in Shallow Water or on Land

- **Major Players: NROC, IMINT, Joint Staff/DDGO, State Dept, USSPACECOM**

- **Procedures In Place Since 1994**
 - Establish NRO Operations Center as focal point for coordination of search and recovery assistance
 - Decision authorities for initiation of  are DNRO, DDNRO, or DDMS

(b)(3)
(b)(1)

~~SECRET//BYE//TK//X1~~

~~SECRET//BYE//TK//XT~~

Slide 7
Sep-02

(b)(1)
(b)(3)

PROPOSED



Decision Criteria

(b)(3)
(b)(1)

1. Likelihood of Survival

- Survivability analysis shows potential for sensitive components to survive to the ground
- Aerospace Fusion Center  is the most likely to be able to provide indications of surviving debris, during reentry

2. Is the Object Recoverable?

- Reentry location determined to be on land or in shallow water (300ft or less)
- Reentry location known with less than 10x10-mile error
- Aerospace Fusion Center  is the most likely to be able to assess impact location

(b)(1)
(b)(3)

3. Additional Inputs/Discussion/Recommendation

- Key players include NROC, IMINT, Aerospace Fusion Center, CMOC Space Vault

***NROC will provide recommendation
on initiation of  to ADDMS,
NRO decision authority per DDNRO delegation***

(b)(1)
(b)(3)

~~SECRET//BYE//TK//XT~~

~~SECRET//BYE//TK//X1~~

Reentry Procedures and Status (1)

- **NROC Coordinate Sensor Support: in work**
 - [redacted] and Space
Surveillance Network
- **IMINT and NROC Develop Criteria for [redacted] Initiation: continuing**
 - Additional [redacted] requested to refine initial reentry survivability analysis
 - As of 18 Sep 02, acquisition of additional [redacted] is not likely
 - IMINT, in coordination with NROC, continues to refine decision criteria
- **Reentry Data Exercise conducted on 18 Sep 2002**
 - Participants: NROC, IMINT, Space Vault, [redacted] AFC, CMO
 - Results: Reviewed reentry planning status to date; practiced real time dissemination of state vector and AFC information; exercised use of Contingency Net; updated offline contact list and e-mail addressee info
- **NROC Status/Recommendations to DDNRO, DDMS, IMINT: in work**

~~SECRET//BYE//TK//X1~~

~~SECRET//BYE//TK//X1~~

Slide 9
20-Sep-02

Reentry Procedures and Status (2)

- **NROC Pre-Event Notifications and Coordination: in work**

- ✓ Joint Staff/DDGO and State Dept for Potential Contingency Support
- ✓ NASA, for Shuttle and/or International Space Station concerns
- ✓ NAVOCEANO, for potential support to Operation [redacted] (b)(1)
(b)(3)
- ✓ NAIC, [redacted] for foreign monitoring concerns
- White House Situation Room via SECRET//TK message from NROC
- Congressional Committees via SECRET//TK message from ROM/Legislative Liaison
- USSPACECOM, to provide coordinated Public Affairs Plan
- Notifications Outside of U.S.
 - State Dept SECRET message to be released to all regional bureaus to notify them that a Military payload will be reentering and that they can obtain updated information from USSPACECOM Public Affairs (POC: [redacted] NRO Rep to State Dept) (b)(3)
 - Commonwealth Partners to be notified at the SECRET//TK level. Information on the reentry releasable to Canada, UK, and Australia. (POCs: [redacted] NRO Office of Policy and [redacted] [redacted]) (b)(3)
- ✓ DRAFT Contingency Message for Embassies from State Dept to be disseminated if NRO determines it is necessary (reentry location determined to be in their area of responsibility). To be sent through intelligence channels [redacted] (b)(1)
(b)(3)

~~SECRET//BYE//TK//X1~~

~~SECRET//BYE//TK//X1~~

Reentry Procedures and Status (3)

- **During Reentry, NROC Manage Operations via Contingency Net**
 - Participants include NROC, IMINT, Space Vault, [REDACTED] Aerospace Fusion Center [REDACTED] Central MASINT Office, [REDACTED]
 - Keep NRO Leadership and Supporting Organizations Informed of Status
 - Provide Real-time Satellite Status and Location Data from Tasked Sensors
 - Provide Near Real-time Determination of Impact Time and Location

- **Post-Reentry**
 - NROC Provide Post-Event Notifications
 - Request USSPACECOM Issue SECRET Reentry Assessment Message
 - DNRO/DDNRO/DDMS/DDNS/affected D&O Director
 - NRO Security and NRO Public Affairs
 - White House Situation Room
 - NROC Contact Joint Staff/DDGO to Initiate (and Request Termination of) Operation [REDACTED] as required by DNRO, DDNRO, or DDMS
 - Notify State Department, if required for diplomatic coordination

(b)(1)
(b)(3)

(b)(1)
(b)(3)

~~SECRET//BYE//TK//X1~~

~~SECRET//BYE//TK//X1~~

Reentry Plan Summary

- **Uncontrolled reentry is predicted for 24 – 28 Sep 02**
- **Reentry will be monitored and reported in accordance with existing processes and procedures**
- **Survivability analysis shows potential for sensitive components to survive to the ground**
 - Coordination is in process to implement emergency search and recovery procedures
- **In the event debris falls on land or into shallow or foreign waters, appropriate assistance will be sought in accordance with existing processes/procedures**
 - Emergency search and recovery assistance from Joint Staff/DDGO
 - Diplomatic notifications through State Department

(b)(1)
(b)(3)

~~SECRET//BYE//TK//X1~~