

EXCLUDED FROM AUTOMATIC
DEGRADING DOD DIR 5200.10
DOES NOT APPLY

~~TOP SECRET~~

NATIONAL RECONNAISSANCE OFFICE
SATELLITE OPERATIONS CENTER

DESCRIPTION OF SIGINT MISSIONS 7166-7235

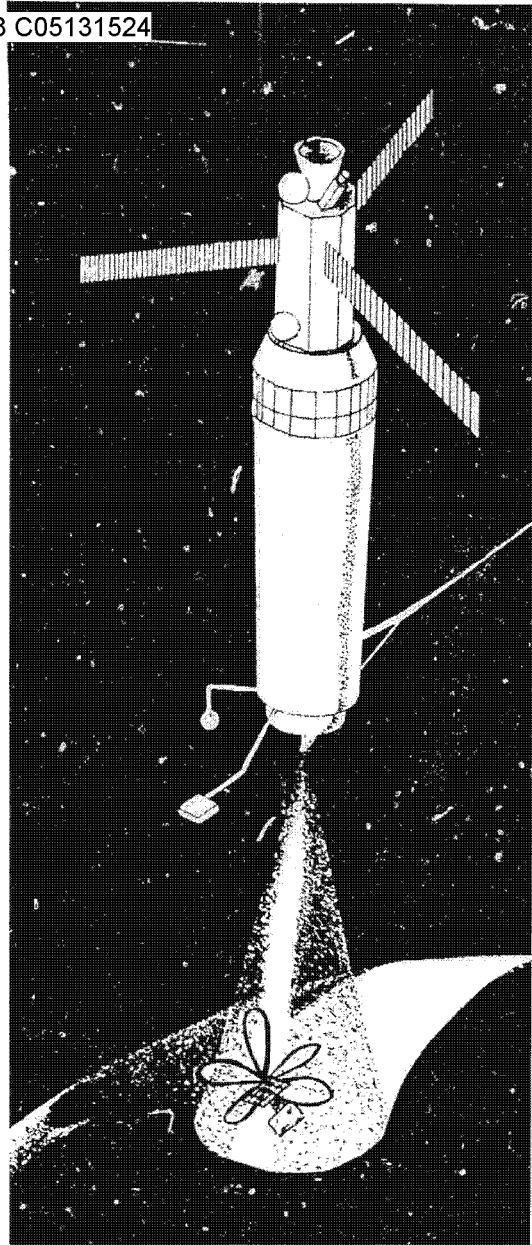

WARNING

This document contains information affecting the national security of the United States within the meaning of the espionage laws U. S. Code Title 18, Sections 793 and 794. The law prohibits its transmission or the revelation of its contents in any manner to an unauthorized person, as well as its use in any matter prejudicial to the safety or interest of the United States or for the benefit of any foreign government to the detriment of the United States. It is to be seen only by personnel especially indoctrinated and authorized to receive information in the designated control channels. Its security must be maintained in accordance with regulations pertaining to the designated controls.

prepared for sigint overhead reconnaissance subcommittee

*MCCARD
R*

handle via **TALENT-KEYHOLE** control only

ON 310

CONTROL NO. TCS-37573-70

COPY NO. 2 OF 7

~~006-12-000~~

GROUP 1
EXCLUDED FROM AUTOMATIC
DOWNGRADING AND DECLASSIFICATION

~~TOP SECRET~~

~~TOP SECRET~~HANDLE VIA
TALENT-KEYI
CONTROL SYSTEM

Mission Description 7166/7235

1. INTRODUCTION

Missions 7166 and 7235 are SIGINT payloads carried aboard a 3-axis-stabilized satellite system which is designed to collect SIGINT data in the 125 to 3300 MHz frequency spectrum. Both payloads collect electronic signals, store intercepted data in digital and analog form, and later transmit this data to various satellite tracking stations throughout the world. This mission description will discuss the technical and operational considerations applicable to each payload.

2. MISSION 7166

2.1 General.

Mission 7166 is a frequency scanning, electronic reconnaissance system which intercepts pulsed and [redacted] radiation from 125 to 2100 MHz. The payload can collect Electronic Order of Battle (EOB) or Technical Intelligence (TI) data. In the EOB mode, the payload digitizes the frequency, pulse repetition interval (PRI), [redacted] time of intercept, and relative position of the intercepted signal. When in the TI mode, the payload records 5 MHz predetected analog data in addition to the digital information just discussed. The major components of the payload are the antennas, the receivers, the recognizers, the frequency matchers, and the Pre-D/[redacted]nit; each will be discussed. Figure 2.1 is a block diagram of the payload. Table 2.1 shows the payload characteristics.

(b)(1)
(b)(3)(b)(1)
(b)(3)(b)(1)
(b)(3)2.2 Antennas.

Two six-arm, cavity-backed, dual-mode, flat-spiral antennas are used for bands 2 and 3. The band 2 antenna is an erectable structure with a diameter of approximately 80 inches. It is deployed from the vehicle by means of a boom to reduce interference effects. The band 3 antenna is also erectable and has a diameter of approximately 40 inches. Band 4 and 5 antennas are fixed structures mounted on the deck of the vehicle. They are 18 and 11 inches in diameter, respectively. Aside from the diameter, the only difference between antennas is that a metal horn is used to reduce vehicle effects in band 4.

Amplitude-differencing circuits process the outputs of the sum and difference modes of the antennas to produce the emitter apex angle (θ). The apex angle is the coverage angle which generates the circumference of the

HANDLE VIA
ENT-KEYHOLE
CONTROL SYSTEM~~TOP SECRET~~
EXCLUDED FROM AUTOMATIC DECLASSIFICATION
DDI DIRECTIVE 5200.10 DOES NOT APPLYCONTROL NO. TCS-37573-70
COPY _____ OF _____ COPIES
PAGE 1 OF 11 PAGES

HANDLE VIA **TALENT KEYHOLE**
CONTROL SYSTEM

Excluded from automatic regrading
DOD Directive 5200.10 does not apply.

~~TOP SECRET~~

Copy of Copies
Page 2 of 11 Pages
Control No. TCS-37573-

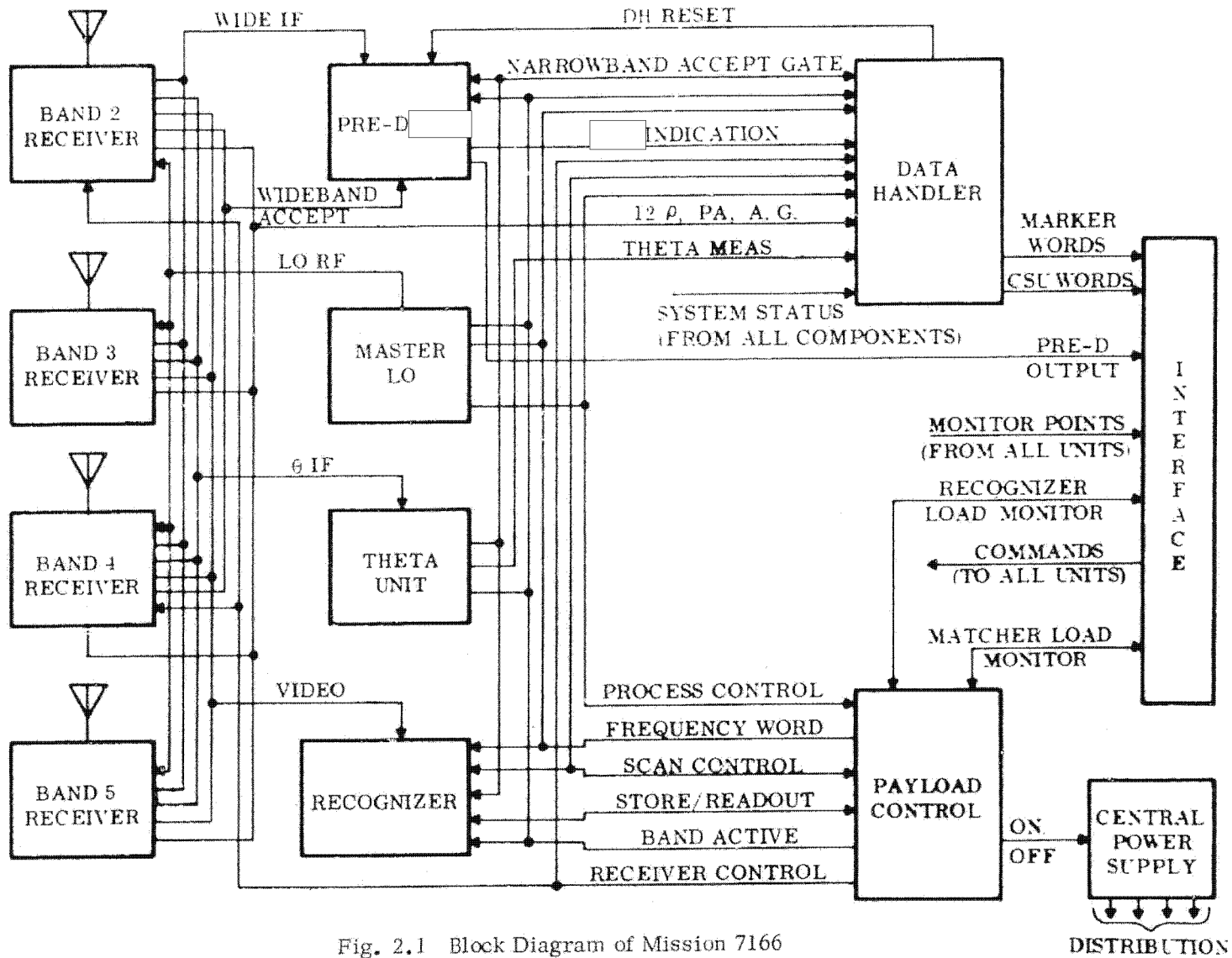

Fig. 2.1 Block Diagram of Mission 7166

(b)(1)
(b)(3)

~~TOP SECRET~~

HANDLE VIA **TALENT KEYHOLE**
CONTROL SYSTEM

~~TOP SECRET~~

HANDLE VIA
TALENT-KEY
CONTROL SYSTEM

Table 2.1

MISSION 7166 PAYLOAD CHARACTERISTICS

Item	Receiver Bands			
	2	3	4	5
Frequency Range (MHz)	125 to 260	260 to 530	530 to 1060	1060 to 2100
Scan Times (sec) (No Intercepts)				
Nominal	4	4	4	4
Alternate	1 or 16	1 or 16	1 or 16	1 or 16
Normal Bandwidth (MHz)	2.0	4.0	4.0	5.0
Narrowband Bandwidth	0.5	NA	1.0	NA
Normal Step Size (MHz)	1.75	1.84	3.5	3.72 or 3.60
Narrowband Step Size	0.4375	NA	0.875	NA
Number of Steps				
Normal	78	156	156	312
Narrowband	312	NA	624	NA
Dwell Time (msec)				
1-Sec Scan	12.7 ±1	6.4 ±1	6.4 ±1	3.2 ±1
4-Sec Scan	51 ±1	25.5 ±1	25.5 ±1	12.7 ±1
16-Sec Scan	204 ±4	102 ±4	102 ±4	51 ±4
PRI (msec)				
Minimum	0.1	0.1	0.1	0.1
Maximum	100	100	100	100
[REDACTED]				
Sensitivity (dbm)	-47	-72	-63	-76
(Selectable	-59	-83	-68	-82
Thresholds)	-65	—	-73	—
	-71	—	-83	—
Dynamic Range (dbm)	From Selected Threshold to -45 dbm.			
Field-of-view (nm) (radius of circle)	Selectable from 103 to 207 (horizon to horizon available for TI only).			

(b)(1)
(b)(3)

HANDLE VIA
TALENT-KEYHOLE
CONTROL SYSTEM

~~TOP SECRET~~
EXCLUDED FROM AUTOMATIC DOWNGRADING
DOD DIRECTIVE 5200.10 DOES NOT APPLY

CONTROL NO. TCS 37573-7
COPY _____ OF _____
PAGE 3 OF 11

~~TOP SECRET~~HANDLE VIA
TALENT-KEYH
CONTROL SYSTEM

ground circle of coverage. The dual-mode design of the antennas also provides a mode phase difference which is processed to produce an indication of emitter azimuth (theta) with respect to the vehicle ground track.

2.3 Receivers.

Mission 7166 processes signals in four frequency bands: band 2, 125 to 260 MHz; band 3, 260 to 530 MHz, band 4, 530 to 1060 MHz, and band 5, 1060 to 2100 MHz. Each band utilizes a dual-channel serially scanned superheterodyne receiver. Bands 2 and 4 are double-conversion superheterodyne receivers and bands 3 and 5 are single-conversion superheterodyne receivers.

There are two basic scan modes, full-band scan and selectable-frequency-range scan. In full-band scan, each receiver remains tuned to a fixed frequency for a dwell time determined by the scan rate selected. If an emitter is not detected, the receiver steps to the next higher frequency and repeats the process until the complete band is scanned. If an emitter is detected, the scan stops for a period of time required to process the emitter or the PRI verification time, whichever is shorter. Scan is resumed upon completion of emitter processing.

In selectable-frequency-range scan, the receivers scan between the frequency limits specified by the frequency matchers. Any or all of the eight frequency matchers may be programmed, and any of the scan modes or rates may be selected when using the frequency matchers.

Bands 2 and 4 have selectable bandwidths, normal and narrowband. When in the narrowband mode, the receiver is step tuned to each narrow frequency range within the normal frequency step. Scan times in the narrowband mode are four times the normal scan rates. The narrowband mode provides increased sensitivity and geopositioning accuracies.

2.4 Recognizer.

The recognizer recognizes desired emitters by comparing stored parameters with the digitized parameters of the intercept. When a recognition occurs, the payload records the intercept on the 5 MHz recorder (see section 4.2). There are eight recognizer words, and each of these words may be enabled or disabled by stored program commands.

HANDLE VIA
LENT-KEYHOLE
CONTROL SYSTEM~~TOP SECRET~~
EXCLUDED FROM AUTOMATIC REGRADING
DDI DIRECTIVE 5200.10 DOES NOT APPLYTCS-37573-71
CONTROL NO. _____
COPY _____ OF _____ COPIES
PAGE 4 OF 11 PAGES

~~TOP SECRET~~

HANDLE VIA
TALENT-KEY
CONTROL SYSTEM

2.5 Frequency Matcher.

The frequency matcher allows narrower frequency limits to be scanned. The magnetic core memory of the frequency matcher has a capability of storing eight words, each with high and low frequency limits and band number. Each of the eight words may be enabled or disabled by command. When a band is activated, the memory is scanned for a word which is associated with that band. The word is clocked from the memory into the shift register and, if that word is enabled, it is compared with the frequency word. A frequency match allows normal scan through the limits stored until the high frequency limit of the memory word is reached. At this point, another word is clocked out of the memory; and the frequency matcher generates a slew scan signal to the scan control until a match occurs between the frequency word and the word in memory. A frequency match resumes normal scan through the limits of the memory word. If no other words are enabled, or if the enabled words do not match the specific frequencies being scanned, the slew signal to the scan control will continue to the end of scan. The frequency matcher may be enabled or disabled. If disabled, the receiver bands will scan normally.

2.6 Predetection

(b)(1)
(b)(3)

The predetection (Pre-D) unit detects the presence of inband signals and converts them to a specified bandwidth and amplitude range. The analog signal output is composed of Pre-D video, reference tones, and a tag burst. The Pre-D video signal is a sinusoidal waveform preserving the pulse width at the Pre-D IF inputs. The reference tones are provided whenever the payload ON command is received. The tag burst occurs whenever the intercept has been within the cone of coverage and has a pulse width greater than the specified minimum.

(b)(1)
(b)(3)

3. MISSION 7235

3.1 General.

(b)(1)
(b)(3)

Mission 7235 is an S-band frequency-scanning, electronic reconnaissance system that precisely measures the location, frequency, of electromagnetic emitters in the 1800 to 3300 MHz frequency range. are also processed. The payload digitizes each parameter measurement and outputs a digital word for each confirmed intercept. This output is stored in one of three core storage units (CSU's) in the satellite. Simultaneously with the

HANDLE VIA
TALENT-KEYHOLE
CONTROL SYSTEM

~~TOP SECRET~~
EXCLUDED FROM AUTOMATIC DOWNGRADING
AND DECLASSIFICATION UNLESS INDICATED OTHERWISE

CONTROL NO. TCS-37573-
COPY _____ OF _____ COPY
PAGE 5 OF 11 PAGE

~~TOP SECRET~~HANDLE VIA
TALENT-KEYHOLE
CONTROL SYSTEM

processing of digital data, the payload matches measured emitter parameters against stored recognizer settings. A match will stop the payload on the emitter frequency and cause the payload to output a pre-detected IF signal and a supplemental digital word for recording on the 5 MHz wideband tape recorder (Data Storage Unit or "DSU"). The major components of the payload are the antennas, the RF and IF assemblies, the data handler, the recognizer, and the frequency matcher; each will be discussed. Table 3.1 lists the Mission 7235 payload characteristics. Figure 3.1 is a block diagram of the Mission 7235 payload.

3.2 Antennas.

Twelve fixed antennas are used, six in the low band (1800 to 2437.5 MHz) and six in the high band (2400 to 3300 MHz). Five antennas in each nest comprise the phase array. The sixth antenna is a spiral-fed horn which provides a difference pattern for amplitude-ratio determination. The phase antennas are circularly polarized and have a nominal gain of 9 db.

Emitter location is determined by measuring the relative phase of the received signal in an interferometer array of five antennas. Simultaneous phase measurements are made in orthogonal directions on each received pulse. Both coarse and fine phase measurements are made; the combination permits phase ambiguities to be resolved. On the ground, the transmitted phase readings are used to compute the direction cosines of the line-of-sight to each emitter. From the direction cosines and ephemeris data, the precise geographical location of each emitter can be computed.

Mission 7235 is capable of locating emitters, with respect to the boresight of the antenna nest, to 7.5 nm with a probability of 95 percent. This accuracy is obtained for target locations out to an elevation angle of 23 deg. from antenna boresight. For received signals with a signal-to-noise ratio less than 20 db (PA \leq -82 dbm), the quoted accuracy is obtained by averaging a minimum of two intercept words (eight pulses). For signal strengths greater than -82 dbm, this accuracy can be obtained with a single pulse measurement. Vehicle alignment, attitude errors, and knowledge of the ephemeris will add to the payload error and increase the overall system error to about 10 nm.

3.3 RF Assembly.

3.3.1 RF Bandpass Filter. Two RF bandpass filters attenuate signals outside the passband from 500 to 10,000 MHz by 50 db minimum. The low-band filter has a bandpass of 1800 to 2450 MHz; the high-band filter, 2400 to 3300 MHz.

HANDLE VIA
ENT-KEYHOLE
CONTROL SYSTEM~~TOP SECRET~~
EXCLUDED FROM AUTOMATIC DOWNGRADING
DOD DIRECTIVE 5200.10 DOES NOT APPLYTCS-37573-70
CONTROL NO. _____
COPY _____ OF _____ COPIES
PAGE 6 OF 11 PAGES

~~TOP SECRET~~

HANDLE VIA
TALENT-KEY
CONTROL SYSTEM

Table 3.1
MISSION 7235 PAYLOAD CHARACTERISTICS

Item	Value						
Frequency Coverage (MHz)	1800 to 3300						
Scan Rate (sec)	5.6 sec nominal (no intercepts), 15 sec in alternate mode						
Search Step Size	2.5						
Dwell Time (msec) Nominal	6.14 (with 2 msec settling time for no intercept) 22.5 (with signal)						
Alternate	22.5 (with 2 msec settling time for no intercept) 45 (with signal)						
PRI (usec) Minimum	100						
Maximum	8192						
Resolution	1.0						
[Redacted]							
Sensitivity (dbm) (Selectable)	-93, -88, or -83						
Dynamic Range (dbm)	40 db above selected threshold						
Field-of-View (nm) Maximum	<table border="0"> <tr> <td style="text-align: center;"><u>Cross Track:</u></td> <td style="text-align: center;"><u>In Track:</u></td> </tr> <tr> <td style="text-align: center;">246</td> <td style="text-align: center;">90.6</td> </tr> <tr> <td style="text-align: center;">Minimum</td> <td style="text-align: center;">66.5</td> </tr> </table>	<u>Cross Track:</u>	<u>In Track:</u>	246	90.6	Minimum	66.5
<u>Cross Track:</u>	<u>In Track:</u>						
246	90.6						
Minimum	66.5						
	(Horizon-to-horizon available for TI only)						

(b)(1)
(b)(3)

HANDLE VIA
TALENT-KEYHOLE
CONTROL SYSTEM

~~TOP SECRET~~
EXCLUDED FROM AUTOMATIC DEGRADING
DOD DIRECTIVE 5200.10 DOES NOT APPLY

TCS-37573-70
CONTROL NO. _____
COPY _____ OF _____ COPIES
PAGE 7 OF 11 PAGES

HANDLE VIA
~~TOP SECRET~~
CONTROL SYSTEM

~~TOP SECRET~~
EXCLUDED FROM AUTOMATIC DOWNGRADING
AND DECLASSIFICATION

CONTROL NO. TCS-37573-70
COPY _____ OF _____
PAGE 8 OF 11 PAGES

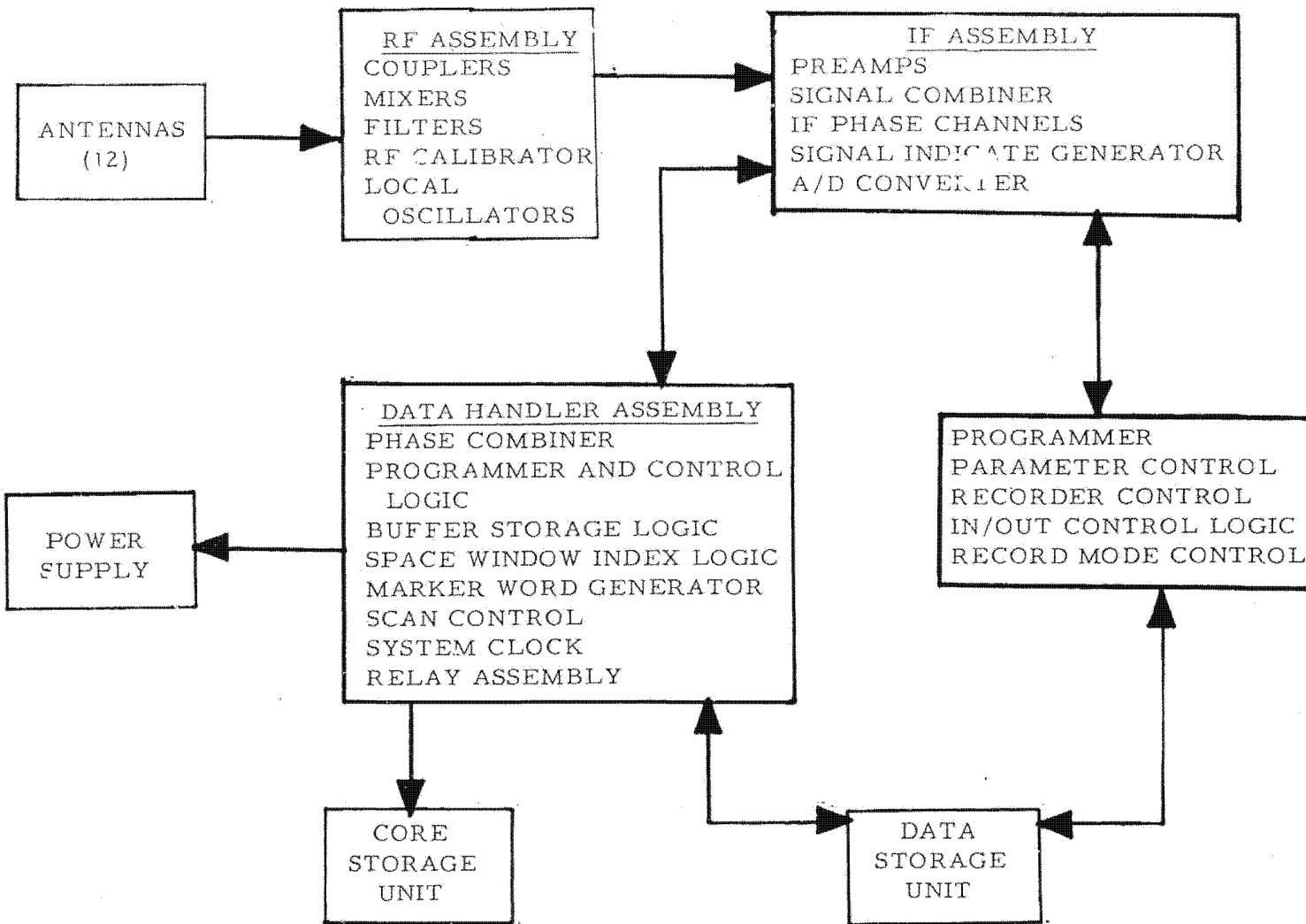

Fig. 3.1 Block Diagram of Mission 7235 Payload

~~TOP SECRET~~

HANDLE VIA
~~TOP SECRET~~
CONTROL SYSTEM

~~TOP SECRET~~HANDLE VIA
TALENT-KEY
CONTROL SYSTEM

3.3.2 Stripline Mixer. The main stripline accepts the seven separate inputs from the system antennas plus the input from the local oscillator. These inputs are mixed in the main stripline and produce eight IF outputs. Five of the IF outputs are amplitude and phase matched to provide direction-finding signals. Two outputs are amplitude matched with a 90-deg phase offset to provide a means for real-image detection. The eighth output is amplitude matched with the phase outputs and is used for amplitude-ratio inhibit detection. A detection circuit is also provided to monitor the local oscillator signal level. The noise figure of the RF front end is established by the mixer. The mixer single sideband noise figure is 8 db maximum.

3.3.3 Local Oscillators. The local oscillators are electronically tuned solid-state microwave YIG oscillators. One oscillator is required for the low band (1780 to 2417.5 MHz) and one for the high band (2420 to 3320 MHz). The digital control count changes 1 count for each 2.5-MHz frequency step. There are 256 steps in the low band 361 frequencies in the high band. Only one band may be operated at one time. Control is provided by a D/A converter.

3.4 IF Assembly.

The IF assembly of the payload contains the following:

Sixteen IF preamplifiers, eight for each RF band

Five phase channels

Signal indicate (SI) generator

Signal combiner

Real/image confirm circuit

A/R inhibit circuit

Two log IF (amplitude) channels

Threshold circuit

Analog-to-digital converter

Frequency confirm circuit

Pulse width confirm circuit

Tag and tone generator

HANDLE VIA
TALENT-KEYHOLE
CONTROL SYSTEM~~TOP SECRET~~EXCLUDED FROM AUTOMATIC DEGRADING
DOD DIRECTIVE 5200.10 GOES NOT APPLY

CONTROL NO. TCS-37573-71

COPY _____ OF _____ COPY

PAGE 9 OF 11 PAGE

~~TOP SECRET~~HANDLE VIA
TALENT-KEYHOLE
CONTROL SYSTEM

The IF assembly provides the circuitry to accept signals from the balanced mixers in the RF assembly and provide the basic input functions to the data handler. The center frequency of the IF channels is 20 MHz. The frequency confirm bandwidth is 3 MHz. The bandwidth of the phase channels is nominally 4.5 MHz. The signal for the predetected output is taken from the IF preamplifiers where the bandwidth is nominally 10 MHz.

3.5 Data Handler.

The data handler processes and encodes received signal parameters, status, time, and attitude information. The data handler also provides buffer storage for the output words and controls the frequency scan circuits.

3.6 Recognizer.

The recognizer is a subassembly which stores frequency, PW, and PRI for matching against the parameters of incoming signals. The parameters are loaded into eight recognizer sets which may be individually enabled/disabled by the programmer. If the parameters of an incoming signal match the parameters of any enabled recognizer set the frequency scan is stopped and a 5 MHz analog recording is made. At the end of the record period, frequency scan resumes.

3.7 Frequency Matcher.

The frequency range of each payload band may be reduced. A partial frequency scan is obtained by loading the desired frequency limits into appropriate payload digital registers. Only one frequency matcher may be used in each of the two payload bands.

4. OPERATIONS

4.1 EOB.

Both Missions 7166 and 7235 collect EOB data in a similar manner. Each payload scans through its frequency range until an intercept is made, at which time the payload scanning stops. Signals which are above a selected sensitivity threshold, within the payload field of view, and within the processing bandwidth qualify as a valid intercept. The payloads digitize the parameters of the intercepted signal, as well as the signal's location relative to the satellite, and then they store this information in two of the three digital storage devices (CSU's) in the satellite. Data can be stored from rev to rev, so that payload EOB operation is not generally readout limited. The frequency scanning range of each payload may be limited by use of frequency

HANDLE VIA
TALENT-KEYHOLE
CONTROL SYSTEM~~TOP SECRET~~
EXCLUDED FROM AUTOMATIC DOWNGRADING
DDO DIRECTIVE #200.13 DOES NOT APPLYCONTROL NO. TCS-37573-70
COPY _____ OF _____ COPIES
PAGE 10 OF 11 PAGES

~~TOP SECRET~~

HANDLE VIA
TALENT-KEYHOLE
 CONTROL SYSTEM

matchers as previously discussed. Mission 7166 has eight frequency matchers, and 7235 has two.

4.2 TI.

In addition to storing digital data, both missions can record analog data on a 5 MHz recorder (Data Storage Unit or "DSU"). There are two recorders (one for redundancy) and each can be operated in several different modes. Either the selected recorder can be operated continuously and assigned to one payload, or the recorder can be shared by both payloads and used only when a valid signal is recognized. In the latter mode, two types of operation are available:

Type 1. If the DSU is not available for recording, receiver scan is resumed after a 125-msec delay for DSU request. If the DSU is available, scan is stopped for recording for a preselected period of 8, 32, or 300 sec.

Type 2. If the DSU is not available for recording, receiver scan is resumed after a 60-sec delay unless a "DSU Available" signal is obtained. If the DSU signal is received, scan is stopped for recording for a preselected time of 4, 16, or 64 sec.

The DSU is defined to be not available for recording one mission if the other mission had previously selected it for use. Data may be stored on the DSU's from rev to rev until a maximum of 80 minutes is recorded. Each payload can store as many as eight different sets of recognizer parameters.

4.3 Command and Control.

The command and control system which supports missions 7166 and 7235 allows extremely flexible operation. Both the CSU's and the DSU's can store data from rev to rev allowing multiple readings. The satellite command programmer generally requires loading only once per day, and it allows the payload configuration to be altered many times on any pass. Multiple payload recognizers and frequency matchers can be used (eight in all cases except the 7235 frequency matchers, where only two are available), and any or all of the recognizers and matchers can be changed during contact by a tracking station.

HANDLE VIA
TALENT-KEYHOLE
 CONTROL SYSTEM

~~TOP SECRET~~
 EXCLUDED FROM AUTOMATIC DOWNGRADING
 DOD DIRECTIVE 5200.10 DOES NOT APPLY

CONTROL NO. TCS-37573-70
 COPY _____ OF _____ COPIES
 PAGE 11 OF 11 PAGES